



Preparation Manual

Computer Science 8–12 (241)

Overview and Exam Framework
Sample Selected-Response Questions
Sample Selected-Response Answers and Rationales

Preparation Manual

Section 3: Overview and Exam Framework Computer Science 8–12 (241)

Exam Overview

Exam Name	Computer Science 8–12
Exam Code	241
Time	5 hours
Number of Questions	100 selected-response questions
Format	Computer-administered test (CAT)

The TExES Computer Science 8–12 (241) exam is designed to assess whether an examinee has the requisite knowledge and skills that an entry-level educator in this field in Texas public schools must possess. The 100 selected-response questions are based on the Computer Science 8–12 exam framework. The exam may contain questions that do not count toward the score. Your final scaled score will be based only on scored questions.

The Standards

Standard I

All teachers use and promote creative thinking and innovative processes to construct knowledge, generate new ideas and create products.

Standard II

All teachers collaborate and communicate both locally and globally using digital tools and resources to reinforce and promote learning.

Standard III

All teachers acquire, analyze and manage content from digital resources.

Standard IV

All teachers make informed decisions by applying critical-thinking and problem solving skills.

Standard V

All teachers practice and promote safe, responsible, legal and ethical behavior while using technology tools and resources.

Standard VI

All teachers demonstrate a thorough understanding of technology concepts, systems and operations.

Standard VII All teachers know how to plan, organize, deliver and evaluate instruction for all students that incorporates the effective use of current technology for teaching and integrating the Technology Applications Texas Essential Knowledge and Skills (TEKS) into the curriculum.

Standard VIII The computer science teacher has the knowledge and skills needed to teach the creativity and innovation; communication and collaboration; research and information fluency; critical thinking, problem solving and decision making; digital citizenship; and technology operations and concepts strands of the Technology Applications Texas Essential Knowledge and Skills (TEKS) in computer science, in addition to the content described in Technology Applications Standards I–VII.

Standard IX The digital forensics teacher has the knowledge and skills needed to teach the creativity and innovation; communication and collaboration; research and information fluency; critical thinking, problem solving and decision making; digital citizenship; and technology operations and concepts strands of the Technology Applications Texas Essential Knowledge and Skills (TEKS) in digital forensics, in addition to the content described in Technology Applications Standards I–VII.

Standard XI The robotics teacher has the knowledge and skills needed to teach the creativity and innovation; communication and collaboration; research and information fluency; critical thinking, problem solving and decision making; digital citizenship; and technology operations and concepts strands of the Technology Applications Texas Essential Knowledge and Skills (TEKS) in robotics, in addition to the content described in Technology Applications Standards I–VII.

Standard XIV The game/application development teacher has the knowledge and skills needed to teach the creativity and innovation; communication and collaboration; research and information fluency; critical thinking, problem solving and decision making; digital citizenship; and technology operations and concepts strands of the Technology Applications Texas Essential Knowledge and Skills (TEKS) in game/application development, in addition to the content described in Technology Applications Standards I–VII.

Domains and Competencies

Domain	Domain Title	Approx. Percentage of Exam	Standards Assessed
I	Technology Applications Core	12.5%	Computer Science 8–12: I–VII
II	Program Design and Development	35%	Computer Science 8–12: VIII
III	Programming Language Topics	40%	Computer Science 8–12: VIII
IV	Specialized Topics	12.5%	Computer Science 8–12: VIII, IX, XI, XIV

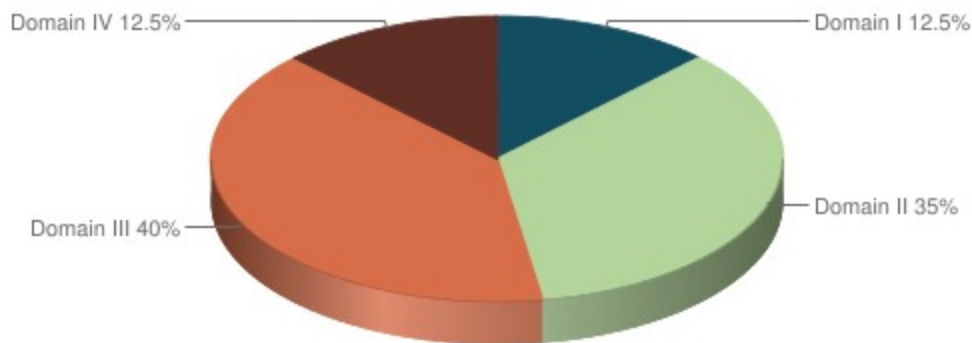

The content covered by this exam is organized into broad areas of content called **domains**. Each domain covers one or more of the educator standards for this field. Within each domain, the content is further defined by a set of **competencies**. Each competency is composed of two major parts:

- The **competency statement**, which broadly defines what an entry-level educator in this field in Texas public schools should know and be able to do.
- The **descriptive statements**, which describe in greater detail the knowledge and skills eligible for testing.

Domain I—Technology Applications Core

Competency 001—The computer science teacher knows technology terminology and concepts; the appropriate use of hardware, software and digital files; and how to acquire, analyze and evaluate digital information.

The beginning teacher:

- Knows and uses technology terminology and concepts appropriate to the task.
- Knows the appropriate use of software and hardware components.
- Demonstrates knowledge of various types of networks (e.g., LAN, WAN, intranets and the Internet).
- Knows how to select, connect and use a variety of local and remote peripheral devices.
- Knows how to manage compatibility issues for a variety of media, file formats (e.g., text, graphics, image, video, audio), file naming conventions, file management structures and digital organization strategies.
- Knows how to evaluate software for quality, appropriateness, effectiveness, efficiency, support and licensing to make decisions regarding its proper acquisition and use.
- Knows how to access, manage and manipulate information from secondary storage devices.
- Knows strategies for searching, acquiring and accessing information from electronic resources.
- Knows how to assess the accuracy and validity of acquired information and how to resolve information conflicts through research and comparison of data from multiple sources.
- Demonstrates knowledge of intellectual property rights (e.g., copyright, Creative Commons, free and open source licensing) when accessing, using, manipulating and editing electronic data.
- Demonstrates knowledge of issues of unacceptable use of computer resources including, but not limited to, cyberbullying and harassment, computer hacking, computer piracy, plagiarism, vandalism, intentional virus setting and invasion of privacy.
- Demonstrates ethical and lawful acquisition of digital information, including the use of established methods to cite sources.

- M. Understands digital safety, privacy rules, digital etiquette, acceptable use of technology and the ethical and legal responsibilities of using social media.
- N. Knows how to use online help and other support documentation to troubleshoot minor technical problems with hardware and software.
- O. Knows how to develop documentation for a variety of products.
- P. Demonstrates knowledge of technology's historical and future impact on society.

Competency 002—The computer science teacher knows how to use technology tools to solve problems, evaluate results and communicate information in a variety of formats for diverse audiences.

The beginning teacher:

- A. Knows how to plan, create, edit, analyze and represent data in documents using general productivity software.
- B. Knows how to explore complex concepts using simulations, models, interactive virtual environments and new technologies to develop hypotheses, modify input and analyze results.
- C. Demonstrates knowledge of how to design and implement procedures to track trends, set timelines and evaluate the progress of products using project management tools for continual improvement in process and product development.
- D. Knows how to evaluate projects for design, purpose, audience and content delivery using various criteria (e.g., project specifications, rubrics).
- E. Knows how to select representative products to be collected and stored in an electronic evaluation tool and to evaluate products for relevance to the assignment or task.
- F. Knows how to plan and design products that are accessible to learners with diverse needs and abilities.

Competency 003—The computer science teacher knows how to plan, organize, deliver and evaluate instruction that effectively utilizes current technology for teaching the Technology Applications Texas Essential Knowledge and Skills (TEKS) to all students.

The beginning teacher:

- A. Knows how to implement developmentally appropriate instructional practices, activities and materials to improve student learning.
- B. Knows how to implement lessons using diverse instructional strategies.
- C. Demonstrates knowledge of issues related to the equitable use of technology for diverse populations.
- D. Knows how to implement instruction that allows students to solve problems by posing questions, collecting data and interpreting results.
- E. Knows how to develop and facilitate collaborative tasks among group members, incorporating diverse perspectives while exploring alternative solutions.
- F. Knows strategies to help students learn how to locate, retrieve, analyze, evaluate, communicate and retain content-related information from a variety of texts and digital sources.
- G. Knows how to evaluate student projects and portfolios using various assessment methods (e.g., formal, informal).
- H. Knows how to promote effective self-evaluation and use of feedback from peers.
- I. Knows the relationship between instruction and assessment.

- J. Knows how to adjust instruction based on assessment results.
- K. Demonstrates knowledge of emerging technology and its role in education.
- L. Knows the importance of self-assessment and planning for professional growth.

Domain II—Program Design and Development

Competency 004—The computer science teacher knows problem-solving strategies and different procedures for program design.

The beginning teacher:

- A. Exhibits knowledge of all phases of the software system life cycle and understands its cyclical nature.
- B. Knows the characteristics of programming design strategies (e.g., design specification, top-down design, step-wise refinement, black box, object-oriented design).
- C. Knows how to apply problem-solving strategies to implement design.
- D. Demonstrates the use of visual organizers (e.g., flow diagrams, Unified Modeling Language [UML]) to document program designs and implementations.
- E. Knows how to create robust programs with emphasis on design to facilitate maintenance, program expansion, reliability, validity and efficiency.

Competency 005—The computer science teacher knows procedures for software development and implementation.

The beginning teacher:

- A. Knows the characteristics of models used in the development of software systems.
- B. Demonstrates the ability to use an integrated development environment (IDE).
- C. Demonstrates knowledge of collaborative strategies for the development of complex software systems (e.g., design/implementation teams, software validation/testing, risk assessment).
- D. Demonstrates the ability to work independently or collaboratively to implement a solution to a problem according to design specifications, identifying data types, objects needed, subtasks to be performed and reusable components from existing code.
- E. Demonstrates the use of programming style conventions (e.g., spacing, indentation, descriptive identifiers, comments, documentation, standardized programming style) to enhance the readability and functionality of code.
- F. Knows how to create robust programs with emphasis on programming style to facilitate maintenance, program expansion, reliability, validity and efficiency.
- G. Knows how to create and use libraries of generic modular code for efficient programming.
- H. Demonstrates the ability to read, evaluate, correct and improve existing code.
- I. Knows how to create robust programs by avoiding runtime errors and handling anticipated errors (e.g., correct handling of input and output, division by zero, type mismatch).
- J. Demonstrates the ability to test programs by entering valid and invalid data; investigating boundary conditions; testing classes, methods and libraries in isolation; and performing stepwise refinement.
- K. Demonstrates the ability to debug program errors (e.g., syntax, runtime, logic) using error messages, reference materials, language documentation and other effective strategies.

Competency 006—The computer science teacher knows computer science terminology and concepts and the characteristics of different programming languages and paradigms.

The beginning teacher:

- A. Knows fundamental computer science vocabulary, including terms related to hardware, software and computational thinking.
- B. Knows specific programming terminology, including terms related to data type, data structures, algorithms and programming constructs.
- C. Knows the differences between low-level and high-level languages.
- D. Knows the differences between compiled and interpreted languages.
- E. Knows the characteristics of and differences in current programming languages and paradigms (e.g., procedural, object-oriented).

Domain III—Programming Language Topics

Competency 007—The computer science teacher correctly and efficiently uses data types, data structures and functions in the development of code.

The beginning teacher:

- A. Understands various computer-related number-base systems and uses them to count, convert and perform mathematical operations.
- B. Understands the characteristics of standard data types in current programming languages (e.g., integer, floating point, character, string, Boolean).
- C. Demonstrates the ability to develop code using constants, variables, data structures and appropriate scope (e.g., local, global).
- D. Understands the difference between primitive and referenced data types (e.g., objects, lists).
- E. Demonstrates the ability to cast between data types and provide object functionality to primitive data types.
- F. Demonstrates effective use of standard libraries (e.g., math, string) in the development of code.
- G. Demonstrates the ability to create user-defined functions and procedures.
- H. Demonstrates understanding of the difference between parameters that are passed by value or by reference.
- I. Knows how to identify object-oriented data types and how to delineate the advantages and disadvantages of object data.
- J. Demonstrates the ability to process data in one-dimensional and multi-dimensional arrays.
- K. Understands how to implement input/output processes (e.g., file, keyboard).
- L. Demonstrates the ability to manipulate text using string processing functions (e.g., concatenation, substring, search).
- M. Understands concepts related to the traversal and processing of abstract data types (e.g., stacks, queues, linked lists, trees, graphs).

Competency 008—The computer science teacher correctly and efficiently uses statements and control structures in the development of code.

The beginning teacher:

- A. Creates mathematical expressions using arithmetic operators (addition, subtraction, multiplication, division, integer division and modulus division).
- B. Develops programs using standard operators (e.g., arithmetic, relational, logical, assignment), operator precedence and short-circuit evaluation.
- C. Demonstrates an understanding of conditional and iterative control structures.
- D. Demonstrates coding proficiency in current programming languages, including an object-oriented language.
- E. Demonstrates understanding of object-oriented design and the relationships (including composition and inheritance) among defined classes, abstract classes and interfaces.
- F. Designs classes that encapsulate data and related methods.
- G. Demonstrates understanding of polymorphism in overloading and overriding features of classes.
- H. Demonstrates the ability to use abstract classes and interfaces to design and implement multi-class programs.

Competency 009—The computer science teacher knows how to construct, compare and analyze various algorithms.

The beginning teacher:

- A. Constructs searching algorithms (e.g., linear and binary searches).
- B. Constructs sorting algorithms including, but not limited to, selection, insertion, merge and quick sorts.
- C. Analyzes the best-, average- and worst-case run-time efficiencies of various algorithms using informal comparisons and Big-O notation.
- D. Traces, compares and uses iterative and recursive algorithms.
- E. Demonstrates an understanding of and the ability to develop common algorithms to solve practical problems.

Domain IV—Specialized Topics

Competency 010—The computer science teacher knows discrete mathematics topics relevant to computer science.

The beginning teacher:

- A. Demonstrates knowledge of terminology and the appropriate application of sets, functions and relations.
- B. Constructs truth tables (for negation, conjunction, disjunction, implication, biconditional, bit operators) and uses them to demonstrate propositional relations.
- C. Converts spoken language statements to appropriate statements in propositional logic.
- D. Demonstrates proficiency in the use of Boolean algebra, including De Morgan's laws, to identify propositional equivalences.
- E. Uses formal logic proofs and logical reasoning to solve problems and evaluate algorithmic complexity.
- F. Computes permutations and combinations of a set and interprets the meaning in context.

- G. Knows how to exhibit, describe and justify mathematical ideas and arguments through the use of precise mathematical language in written or oral communication.

Competency 011—The computer science teacher knows digital forensics topics.

The beginning teacher:

- A. Understands that digital forensics involves the recovery and investigation of material found in digital devices, often in relation to computer crime.
- B. Demonstrates knowledge of legal, illegal, ethical and unethical information gathering methods; possible gray areas; and ways in which developing laws and guidelines affect digital forensics practices.
- C. Understands that digital forensics involves the application of tools in a variety of investigations related to malicious attacks (e.g., worm infections, malware, phishing incidents, viruses, Trojans, rootkits, email threats).
- D. Identifies and describes businesses and government agencies that use digital forensics.
- E. Demonstrates knowledge of how digital forensics fits in the workplace and how to establish guidelines, procedures and recommendations for the use of digital forensics tools.
- F. Knows how to describe the function and use of digital forensics toolkits in the analysis of network traffic data and data files from various storage media.

Competency 012—The computer science teacher knows robotics topics.

The beginning teacher:

- A. Demonstrates knowledge of technology concepts, systems and operations as they apply to robotics.
- B. Knows how to utilize the design process to prototype, construct, evaluate, refine and document the development of a robot.
- C. Demonstrates the use of computers to manipulate a robot.
- D. Develops algorithms to move and provide interaction with a robot, including applying instructions, collecting sensor data and performing simple tasks (e.g., following lines, moving objects, avoiding obstacles).
- E. Knows how to explore the effects robots have on culture and society.
- F. Knows how to use software applications to simulate the behavior of robots of varying complexity, present design concepts and test solution strategies.

Competency 013—The computer science teacher knows game and mobile application development topics.

The beginning teacher:

- A. Demonstrates an understanding of the software-development process specifically applied to mobile and desktop game applications.
- B. Demonstrates knowledge of the basic game design process and elements.
- C. Knows the fundamentals of game art, including the look and feel, graphics coordinate system, basics of color theory and image rendering.

- D. Demonstrates an understanding of the user experience and knows how to create effective user interfaces, game rules and instructions.
- E. Knows how to use board games to research and collect game-play data.
- F. Demonstrates an understanding of game programming essentials, including event-driven programming and collision detection.
- G. Knows how to use a simulation tool to imitate a mobile device's functionality.

Preparation Manual

Section 4: Sample Selected-Response Questions Computer Science 8–12 (241)

This section presents some sample exam questions for you to review as part of your preparation for the exam. To demonstrate how each competency may be assessed, sample questions are accompanied by the competency that they measure. While studying, you may wish to read the competency before and after you consider each sample question. Please note that the competency statements do not appear on the actual exam.

For each sample exam question, there is a correct answer and a rationale for each answer option. The sample questions are included to illustrate the formats and types of questions you will see on the exam; however, your performance on the sample questions should not be viewed as a predictor of your performance on the actual exam.

Domain I—Technology Applications Core

Competency 001—The computer science teacher knows technology terminology and concepts; the appropriate use of hardware, software and digital files; and how to acquire, analyze and evaluate digital information.

1. Which of the following is the principal advantage of saving a word processing document in rich-text format?
- A. The document can be viewed in any Web browser.
 - B. A formatted document can be transferred between different applications.
 - C. The document can take up less space in memory.
 - D. A formatted document can be scanned for viruses when sent as an email attachment.

Answer _____

2. Which of the following would most likely be considered unacceptable use of information by a teacher?
- A. Using the school district's database to determine gender distribution in local schools
 - B. Using the Internet history on a classroom computer to audit student Internet use
 - C. Using students' personal data to create a mailing list for a local charity
 - D. Using classroom records to determine recipients of academic awards

Answer _____

3. Consider the uniform resource locator (URL) <https://example.net/index.html>. Which of the following are contained in the URL?
- A. Browser name
 - B. Email address
 - C. File name
 - D. Host name

- E. MAC address
- F. Protocol

Answer _____

Competency 002—The computer science teacher knows how to use technology tools to solve problems, evaluate results and communicate information in a variety of formats for diverse audiences.

4. Students in a Texas classroom have been communicating with a class in New York by videoconference. The two classes find that the images they receive from each other occasionally freeze for up to 30 seconds before the video continues. This type of problem can most often be solved by

- A. increasing bandwidth.
- B. upgrading cameras.
- C. increasing video resolution.
- D. upgrading monitors.

Answer _____

5. Which of the following is the most appropriate format for graphics that are to be embedded within an Internet document?

- A. BMP
- B. TIFF
- C. PNG
- D. HTML

Answer _____

6. Suppose that the class grade for a six-week period is based on 3 tests (T1, T2, T3), each of which counts for 15%, 4 quizzes (Q1, Q2, Q3, Q4), each of which counts for 10%, and a homework notebook (HW), which counts for 15%. The grades are recorded in a spreadsheet similar to the one below.

	A	B	C	D	E	F	G	H	I	J
1	Name	T1	T2	T3	Q1	Q2	Q3	Q4	HW	AVG
2	Jane	87	92	80	76	79	87	74	90	
3	Joe	91	85	77	78	88	96	90	92	
4	Bill	65	72	70	80	81	74	77	80	
5	Brenda	96	88	91	76	91	100	74	98	

Which of the following formulas would be a correct calculation of the six-week weighted average for Jane?

- A. $=(B2+C2+D2+E2+F2+G2+H2+I2)/8$
- B. $=(B2+C2+D2+I2)*0.15+(E2+F2+G2+H2)*0.1$

C. $=(B^2+C^2+D^2+I^2)*15+(E^2+F^2+G^2+H^2)*10$

D. $=(B^2+C^2+D^2+I^2)/15+(E^2+F^2+G^2+H^2)/10$

Answer _____

Competency 003—The computer science teacher knows how to plan, organize, deliver and evaluate instruction that effectively utilizes current technology for teaching the Technology Applications Texas Essential Knowledge and Skills (TEKS) to all students.

7. A teacher has assigned students several topics to discuss outside of class using an electronic form of communication. The teacher wants the students' messages to be organized by topic and wants to have all historical messages available to students. To facilitate this type of communication most effectively, the teacher should have students

- A. participate in a threaded discussion group.
- B. send email messages with attached document files.
- C. update pages on the class's Web site.
- D. engage in dialogue in a real-time chat room.

Answer _____

8. A computer science teacher is going to have the students in a class read an article from a technology journal as homework. Which of the following instructional strategies best ensures that the students will fully understand the material?

- A. The teacher asks the students the following day if they fully understand the material.
- B. The teacher asks the students to take notes on the material as they are reading it.
- C. The teacher assigns problems or questions on key concepts for the students to complete after they have finished reading the material.
- D. The teacher reviews the material in a class presentation the following day and instructs the students to take notes on the presentation.

Answer _____

Domain II—Program Design and Development

Competency 004—The computer science teacher knows problem-solving strategies and different procedures for program design.

9. Consider the following flowchart diagram, where `arr[0..len-1]` is an integer array of length `len`. Assume that the elements `arr[0]`, `arr[1]`, ..., `arr[len-1]` have already been initialized.

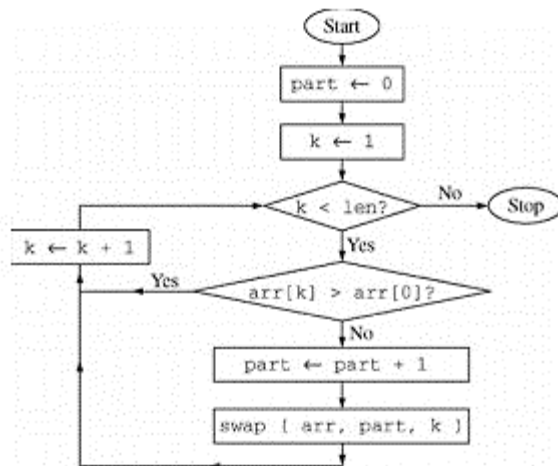

Which of the following pseudocode segments implements the algorithm in the flowchart?

- A. `int part ← 0`
`int k ← 1`
`while (k < len)`
 `if (arr[k] ≤ arr[0]`
 `part ← part + 1`
 `swap (arr, part, k)`
 `end if`
 `k ← k + 1`
`end while`
- B. `int part ← 0`
`int k ← 1`
`while(k < len)`
 `k ← k + 1`
 `if (arr[k] ≤ arr[0])`
 `part ← part + 1`
 `swap (arr, part, k)`
 `end if`
`end while`
- C. `int part ← 0`
`int k ← 1`
`while (k < len)`
 `if (arr[k] > arr[0])`
 `part ← part + 1`
 `swap (arr, part, k)`
 `end if`
 `k ← k + 1`
`end while`
- D. `int part ← 0`
`int k ← 1`
`while(k < len)`

```

    k ← k + 1
    if ( arr[k] > arr[0] )
        part ← part + 1
        swap ( arr, part, k )
    end if
end while

```

Answer _____

10. Which of the following best describes the purpose of generating a flowchart as part of the design of a computer program?

- A. To test and maintain the efficiency of the overall program
- B. To present the steps needed to solve the programming problem
- C. To ensure that all methods are appropriately linked
- D. To determine the necessary number of global and local variables

Answer _____

STU
-abc : int
-def : float
+ghi() : int
+jkl() : float
+mno() : char

11. Which of the following best describes the information conveyed by the UML class diagram above?

- A. A class named `STU` contains two private fields and three public methods.
- B. A class named `STU` contains two public fields and three private methods.
- C. A class named `STU` contains two private methods and three public fields.
- D. A class named `STU` contains two public methods and three private fields.

Answer _____

12. Consider the following algorithm for finding the maximum value in an integer array $x[0..n-1]$ of length n , where the index of array x starts at 0.

- I. Initialize a variable, `max`, which will hold the largest value found in the array so far.
- II. Go through the array elements and compare each value to `max`.
- III. If a value is greater than `max`, set it as the new value of `max`.
- IV. After going through the entire array, the maximum value in the array is the value of `max`.

Which of the following flowcharts represents the algorithm?

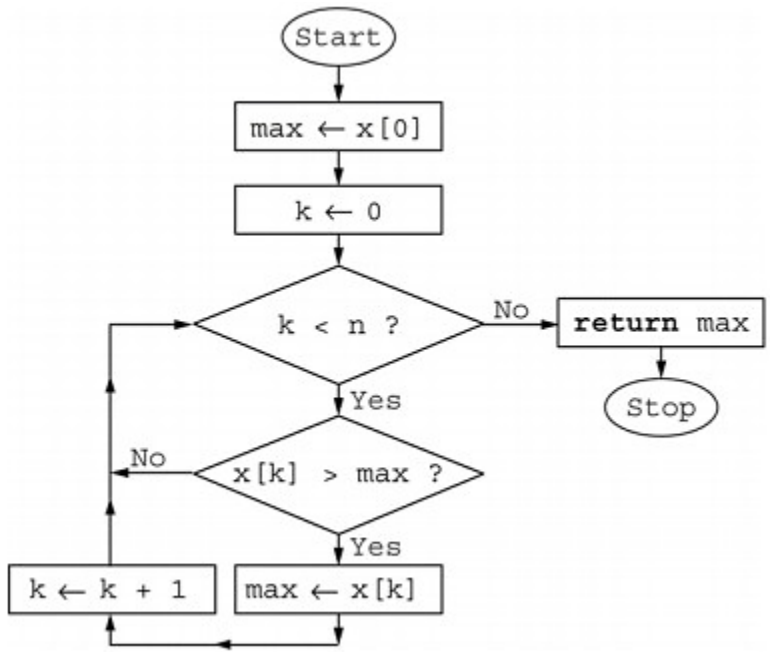

A.

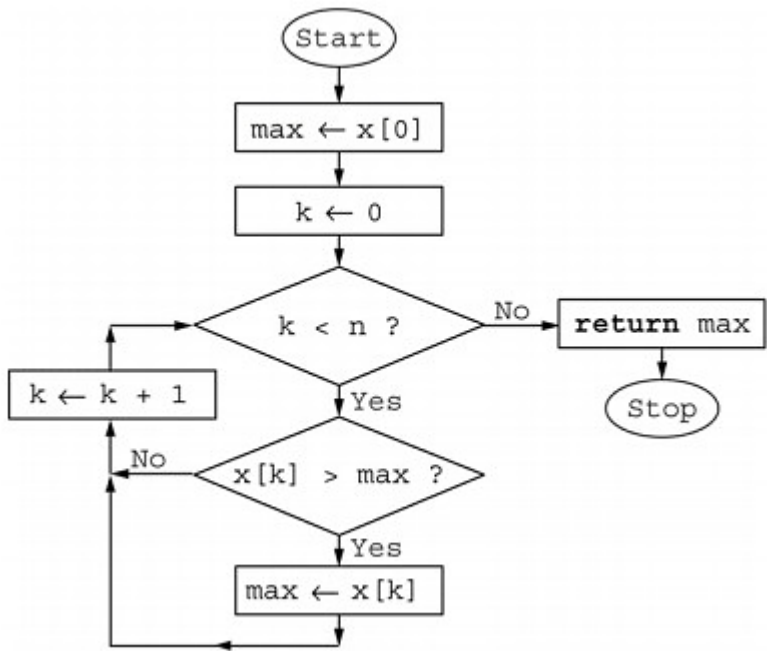

B.

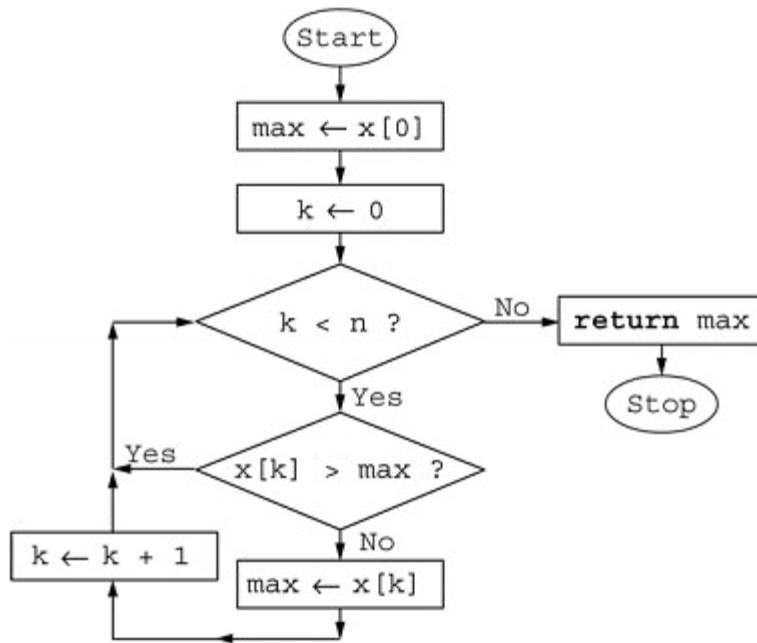

C.

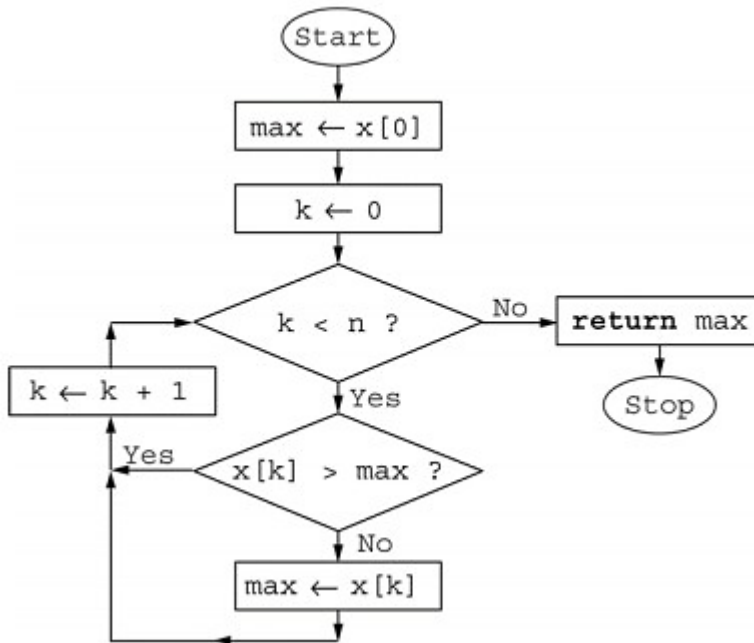

D.

Answer _____

Competency 005—The computer science teacher knows procedures for software development and implementation.

13. A software system is to be developed for which the requirements are well understood and the risk of failure is minimal. To meet these requirements, which of the following software development models would be most appropriate to use?

- A. Chaos
- B. Incremental

- C. Spiral
- D. Waterfall

Answer _____

14. The most appropriate way to use a library of program code is to access the

- A. methods or functions by way of the interface.
- B. implementation details of the methods or functions.
- C. methods or functions by way of the source code.
- D. documentation of the methods or functions.

Answer _____

15. Consider the following pseudocode segment with integer variables, where the precondition at the beginning of the segment is missing.

```
// missing precondition
x ← x + 1
y ← y + x
// postcondition: y == 2 * x
```

Which of the following would be a valid precondition for the code segment above?

- A. $y == x - 1$
- B. $y == x$
- C. $y == x + 1$
- D. $y == x + 2$

Answer _____

16. Consider the following pseudocode segment with floating point variables, where the function squareRoot is the standard square root function.

```
if ( /* missing condition */ )
    answer ← squareRoot ( a / ( b - c ) )
end if
```

Assume the programming language evaluates compound Boolean expressions from left to right and short-circuits the logical operators **and** and **or** as soon as the result of an expression is known. Which of the following could replace /* missing condition */ so the code segment would not generate a run-time error?

- A. $b - c \neq 0$
- B. $a / (b - c) \geq 0$
- C. $(b - c \neq 0) \text{ and } (a / (b - c) \geq 0)$
- D. $(b - c \neq 0) \text{ or } (a / (b - c) \geq 0)$

Answer _____

Competency 006—The computer science teacher knows computer science terminology and concepts and the characteristics of different programming languages and paradigms.

17. Which of the following techniques is used by most programming languages to intercept events that disrupt the normal flow of a program's execution?

- A. Code security
- B. Flow control
- C. Exception handling
- D. Error detection

Answer _____

18. If execution speed and direct communication with devices such as controllers and processors are essential to the success of a project, which of the following programming languages would be most appropriate to use?

- A. C
- B. Java
- C. PHP
- D. Visual Basic

Answer _____

19. How many bytes are needed for an array of 1,000 integers if each integer requires 32 bits of storage?

- A. 1,000 bytes
- B. 4,000 bytes
- C. 16,000 bytes
- D. 32,000 bytes

Answer _____

20. Which of the following is unique to the object-oriented paradigm of programming?

- A. Support for abstract data types (ADTs)
- B. Support for the concepts of encapsulation and inheritance
- C. Support for control structures
- D. Support for the practice of code reuse

Answer _____

Domain III—Programming Language Topics

Competency 007—The computer science teacher correctly and efficiently uses data types, data structures and functions in the development of code.

21. Which of the following is most efficient for manipulating a list that contains integers and is of predefined size?

- A. A stack
- B. A linked list
- C. An array
- D. A sequential file

Answer _____

22. A programmer is developing a program to read strings from a file and store the strings in a data structure. The strings are unordered in the file but must be accessible in alphabetical order in the data structure. The program must also be able to add and remove strings from the data structure.

Which of the following data structures is the best choice for the program so that the requirements for creating the data structure, adding and removing elements, and accessing individual elements are met as efficiently as possible?

- A. A binary search tree
- B. A linked list
- C. A queue
- D. A stack

Answer _____

23. Consider the following pseudocode procedure `calc`, where the first and second parameters are passed by value and the third and fourth parameters are passed by reference. That is, actual parameters passed to formal parameters `w` and `x` are passed by value, while those passed to formal parameters `y` and `z` are passed by reference.

```
procedure calc ( pass-by-value int w,  
                 pass-by-value int x,  
                 pass-by-reference int y,  
                 pass-by-reference int z )  
  
    w ← w + 1  
    x ← x * 2  
    y ← y + 3  
    z ← z * 4  
  
end procedure
```

What are the values of `a` and `b` at the end of the code fragment below?

```
int a ← 5  
int b ← 6  
calc ( a, a, b, b )
```

- A. `a = 5` and `b = 24`
- B. `a = 5` and `b = 36`
- C. `a = 10` and `b = 6`

D. $a = 12$ and $b = 6$

Answer _____

24. Consider a class `Stack` defined with methods `push (x)`, `pop ()` and `peek ()` that implement a stack data structure. (Note that `void push (int x)` pushes the integer x onto the top of the stack; `int pop ()` removes the integer at the top of the stack and returns that integer; `int peek ()` returns the integer at the top of the stack without removing it from the stack.)

Consider the following pseudocode fragment, where S is a `Stack` instance that will hold integers.

```
Stack S ← new Stack ()
S.push ( 4 )
S.push ( 3 )
S.push ( S.peek () + S.peek () )
S.push ( S.pop () * S.pop () )
print ( S.peek () )
```

What is printed by the last line of code?

- A. 18
- B. 21
- C. 28
- D. 32

Answer _____

25. What is the sum of the binary (base 2) number 1100_2 and the hexadecimal (base 16) number 3_{16} ?

- A. F_{16}
- B. 15_{16}
- C. 1003_{10}
- D. 1103_{18}

Answer _____

26. Consider the following array initialization, where array x has been declared properly but the declaration is not shown.

```
x ← { 0, { 1, { 2, 3 } }, 4 }
```

Which of the following diagrams best represents array x ?

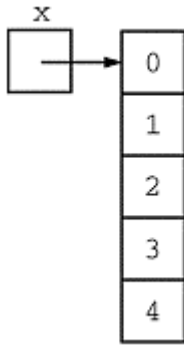

A.

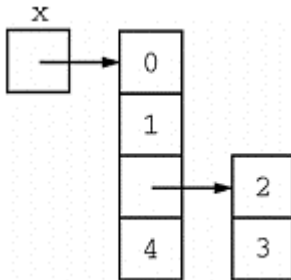

B.

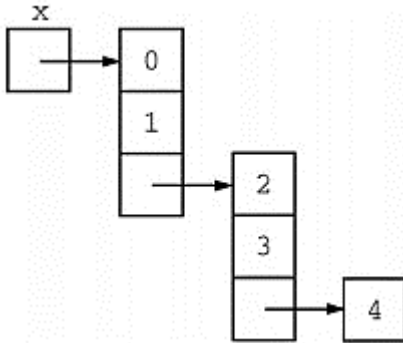

C.

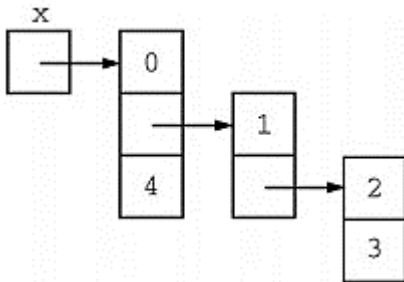

D.

Answer _____

27. Consider the following pseudocode segment, where x and y are integer arrays of length 5. The index of each array starts at 0.

```
int[] x ← { 1, 2, 3, 4, 5 }
int[] y ← { 8, 6, 4, 2, 0 }
```

What is the value of the expression $x[y[3]] + y[x[1]]$?

- A. 7
- B. 8

C. 11

D. 12

Answer _____

28. Assume that a singly linked list of integers is implemented using the following pseudocode class declaration.

```
class Node
  int data
  Node next
end Node
```

Consider the following (incomplete) method `g`, which takes the head of a singly linked list of integers as argument.

```
void g ( Node x )
  if ( x ≠ null )
    /* missing code segment */
  end if
end g
```

Which of the following would correctly complete the method `g` so that the call `g (x)` prints out the contents of `x` in reverse order?

- A. `print x.data`
`x ← x.next`
- B. `print x.data`
`g (x.next)`
- C. `g (x.next)`
`print x.data`
- D. `g (x)`
`print x.data`

Answer _____

Competency 008—The computer science teacher correctly and efficiently uses statements and control structures in the development of code.

29. Consider the following pseudocode functions, where each print statement prints on a separate line of output and then executes a line feed.

```
void f1 ( int n )
  int k ← 0
  do {
    k ← k + 1
    print k
  } while ( k < n )
end f1
void f2 ( int n )
  int k ← 0
```

```

    while ( k < n )
        k ← k + 1
        print k
    end while
end f2

```

Which of the following describes all the values of the input n for which functions f_1 and f_2 print the same sequence of numbers?

- A. $n > 0$
- B. $n \geq 0$
- C. $n < 0$
- D. $n \leq 0$

Answer _____

30. Consider the following pseudocode fragment, where x is an integer variable initialized to a nonnegative integer value.

```

// x is a nonnegative integer
int sum
x ← x / 2 // integer division; truncates fractions
for (sum ← 1; x > 0; x ← x / 2 )
    sum ← sum + 1
end for

```

Which of the following will calculate the same value of sum as the fragment above?

- A.

```
int sum ← 0
x ← x / 2
while ( x ≥ 0 )
    sum ← sum + 1
    x ← x / 2
end while
```
- B.

```
int sum ← 1
x ← x / 2
while ( x ≥ 0 )
    sum ← sum + 1
    x ← x / 2
end while
```
- C.

```
int sum ← 0
do {
    sum ← sum + 1
    x ← x / 2
} while ( x > 0 )
```
- D.

```
int sum ← 1
do {
    sum ← sum + 1
```



```
    x ← x / 2
} while ( x > 0 )
```

Answer _____

31. Consider the following pseudocode fragment with integer variables.

```
total ← 0
x ← 1

while ( x < ( 2 * n ) )
    if ( ( x % 2 ) == 1 ) // if x is odd
        total ← total + x
    end if
    x ← x + 1
end while

print ( total )
```

Assume that n has been initialized with a positive integer value. What value is printed when the code fragment is executed?

- A. 0
- B. n
- C. $2n$
- D. n^2

Answer _____

32. In a distribution center, x identical items are to be placed into a number of identical boxes. If at most y items fit in a box, which of the following expressions describes the maximum possible number of full boxes? (In the expressions below, $/$ represents decimal division and \backslash represents integer division.)

- A. x / y
- B. $(x / y) + (x \% y)$
- C. $x \backslash y$
- D. $(x \backslash y) + (x \% y)$

Answer _____

33. Consider the following arithmetic expression.

```
6 / 3 - 7 % 2 + 4 * 5
```

According to standard operator precedence and standard operator associativity, what is the fourth operation performed when calculating the value of the expression?

- A. Addition
- B. Modulus (remainder)
- C. Multiplication

D. Subtraction

Answer _____

34. Consider an integer array x of length 25, where the index of the array starts at 0. Which of the following pseudocode segments prints the elements of the array in reverse order?

- A.

```
for ( int i ← 0; i < 25; i ← i + 1 )
    print x[i + 1]
end for
```
- B.

```
for ( int i ← 0; i < 25; i ← i + 1 )
    print x[i]
end for
```
- C.

```
for ( int i ← 25; i > 0; i ← i - 1 )
    print x[i - 1]
end for
```
- D.

```
for ( int i ← 25; i > 0; i ← i - 1 )
    print x[i]
end for
```

Answer _____

Competency 009—The computer science teacher knows how to construct, compare and analyze various algorithms.

35. Which of the following represents the average-case performance of a quicksort algorithm?

- A. $O(n)$
- B. $O(\log_2 n)$
- C. $O(n^2)$
- D. $O(n \log_2 n)$

Answer _____

36. Consider the following pseudocode function, where each print statement prints on a separate line of output and then executes a line feed.

```
void h ( int n )
    if ( n ≥ 4 )
        h ( n / 2 )
    end if
    print n
end h
```

What is printed when the call $h (16)$ is executed?

- A. 2
- B. 16

C. 16

8

4

2

D. 2

4

8

16

Answer _____

37. A specific sorting algorithm begins by finding the largest element of an array and swapping that element with the last element of the array. Which of the following sorting algorithms fits this description?

A. Quicksort

B. Insertion sort

C. Heapsort

D. Selection sort

Answer _____

38. Consider the following pseudocode binary search function, which returns the largest array index from one given index to another, k , such that $a[k] \leq x$.

```
// precondition 1: integer array a is sorted in
//           ascending order
// precondition 2:  $0 \leq \text{first} < \text{last} < \text{length of array a}$ 
// precondition 3:  $a[\text{first}] \leq x < a[\text{last}]$ 
int f ( int array a, int x, int first, int last )
    while ( first + 1  $\neq$  last )
        int mid  $\leftarrow$  ( first + last ) / 2 // integer
                                   // division

        if ( x < a[mid] )
            last  $\leftarrow$  mid
        else
            first  $\leftarrow$  mid
        end if
    end while
    return first
end f
```

Consider the following incomplete, equivalent, recursive implementation.

```
Int g ( int array a, int x, int first, int last )
    if ( first + 1 == last )
        return first
    end if
```

```

    int mid ← ( first + last ) / 2
    // missing code block
end g

```

Which of the following could replace the missing code block so that the recursive function will work as intended?

- A. `if (x ≥ a[mid])`
 `return g (a, x, first, mid)`
`end if`
 `return g (a, x, mid, last)`
- B. `if (x ≥ a[mid])`
 `return g (a, x, mid, first)`
`end if`
 `return g (a, x, last, mid)`
- C. `if (x ≥ a[mid])`
 `return g (a, x, mid, last)`
`end if`
 `return g (a, x, first, mid)`
- D. `if (x ≥ a[mid])`
 `return g (a, x, last, mid)`
`end if`
 `return g (a, x, mid, first)`

Answer _____

39. Consider the following pseudocode function.

```

// precondition: n and k are nonnegative integers
int f ( int n, int k )
    if ( k * n == 0 )
        return 1
    else
        return f ( n - 1, k - 1 ) + f ( n - 1, k )
    end if
end f

```

What value is returned by the call `f (4, 2)` ?

- A. 4
 B. 5
 C. 7
 D. 11

Answer _____

40. Consider the following pseudocode segment with integer variables that implements a selection sort. Assume that A is an integer array of length n with indexing that starts at 0.

```

for ( int  $j \leftarrow 0$ ;  $j < n - 1$ ;  $j \leftarrow j + 1$  )
    int  $x \leftarrow j$ 
    for ( int  $i \leftarrow j + 1$ ;  $i < n$ ;  $i \leftarrow i + 1$  )
        // missing code block
    end for
    if (  $x \neq j$  )
        swap (  $A[x]$ ,  $A[j]$  ) // swap the two array entries
    end if
end for

```

Which of the following could replace the missing code block so that the code segment will work as intended?

A. **if** ($A[x] > A[i]$)

$x \leftarrow i$

end if

B. **if** ($A[x] > A[i]$)

$A[x] \leftarrow A[i]$

end if

C. **if** ($x > i$)

$x \leftarrow i$

end if

D. **if** ($x > i$)

$A[x] \leftarrow A[i]$

end if

Answer _____

41. Consider the following pseudocode, which implements an insertion sort.

```

// precondition 1: A is an array of integers.
// precondition 2: The length of array A is n.
// precondition 3: The index of array A starts at 0.
int[] insertionSort ( pass-by-reference int[]  $A$ , int  $n$  )
    for ( int  $j \leftarrow 1$ ;  $j \leq n - 1$ ;  $j \leftarrow j + 1$  )
        int  $temp \leftarrow A[j]$ 
        int  $k \leftarrow j - 1$ 
        while( (  $k \geq 0$  ) and (  $A[k] > temp$  ) )
             $A[k + 1] \leftarrow A[k]$ 
             $k \leftarrow k - 1$ 
        end while
         $A[k + 1] \leftarrow temp$ 
    end for
    return  $A$  // returns the sorted array
end insertionSort

```

Which of the following best describes the average running time of `insertionSort`?

- A. $O(1)$
- B. $O(\log n)$
- C. $O(n \log n)$
- D. $O(n^2)$

Answer _____

42. Consider the following three pseudocode procedures.

```
Procedure 1  
procedure p1 ( int s, int e )  
    int k  
    for ( k ← s; k < e; k ← k + 2 )  
        print ( k )  
    end for  
end procedure p1
```

```
Procedure 2  
procedure p2 ( int s, int e )  
    do {  
        s ← s + 2  
        print ( s )  
    } while ( s < e )  
end procedure p2
```

```
Procedure 3  
procedure p3 ( int s, int e )  
    print ( s )  
    if ( s < e )  
        p3 ( s + 2 )  
    end if  
end procedure p3
```

Assume that `s` and `e` have been initialized with integer values. Which of the following statements about the output of the procedures is true?

- A. For each pair (s, e) , the three procedures will produce the same output.
- B. For each pair (s, e) , procedure 1 and procedure 2 will produce the same output, but for some pairs (s, e) , procedure 1 and procedure 3 will produce different output.
- C. For each pair (s, e) , procedure 2 and procedure 3 will produce the same output, but for some pairs (s, e) , procedure 1 and procedure 2 will produce different output.
- D. For some pairs (s, e) , the three procedures will produce three different outputs.

Answer _____

Domain IV—Specialized Topics

Competency 010—The computer science teacher knows discrete mathematics topics relevant to computer science.

43. Which of the following truth tables correctly represents the Boolean expression $(p \wedge q) \leftrightarrow (p \vee q)$?

A.	p	q	$(p \wedge q) \leftrightarrow (p \vee q)$
	1	1	0
	1	0	1
	0	1	1
	0	0	0

B.	p	q	$(p \wedge q) \leftrightarrow (p \vee q)$
	1	1	1
	1	0	0
	0	1	0
	0	0	1

C.	p	q	$(p \wedge q) \leftrightarrow (p \vee q)$
	1	1	1
	1	0	1
	0	1	1
	0	0	0

D.	p	q	$(p \wedge q) \leftrightarrow (p \vee q)$
	1	1	1
	1	0	0
	0	1	0
	0	0	0

Answer _____

44. Consider propositions p and q , defined as follows.

p : I go for a run.

q : The sky is dark.

Which of the following is equivalent to the compound proposition "I don't go for a run when the sky is dark"?

A. $p \Rightarrow q$

B. $\neg p \Rightarrow q$

C. $q \Rightarrow \neg p$

D. $\neg q \Rightarrow p$

Answer _____

45. If p and q are propositions, which of the following is the contrapositive of the implication $p \Rightarrow q$?

A. $q \Rightarrow p$

B. $\neg q \Rightarrow \neg p$

C. $q \vee p$

D. $q \wedge p$

Answer _____

Competency 011—The computer science teacher knows digital forensics topics.

46. Which of the following describes how data remanence is relevant to digital forensics?

A. It allows the recovery of digital data even though file deletion has occurred.

B. It determines whether data are preserved or lost when a computer is turned off.

C. It ensures that collected evidence is admissible as evidence in a court of law.

D. It establishes who has authorization to monitor and collect network traffic data.

Answer _____

47. Which of the following best describes a computer worm?

A. Malware that does not replicate itself but spreads through social engineering

B. Malware that replicates by attaching itself to a word processing document

C. Malware that replicates by attaching itself to an executable program

D. Malware that replicates itself as stand-alone software

Answer _____

Competency 012—The computer science teacher knows robotics topics.

48. A robot's programming system uses the command `move[motor] ← value`, where `motor` identifies a particular motor and `value` is an integer amount of speed, with a positive value indicating forward movement, a negative value indicating backward movement, and 0 indicating a stop. For example, the command `move[left] ← 99` will cause the left motor to move forward at a speed of 99.

A student is programming a two-wheel-drive robot to travel through a maze and is having trouble with the corners. The robot swings wide and goes out of bounds. A segment of the code being used for a right turn is similar to the code below, where `left` is the left wheel motor (from the robot's perspective), `right` is the right wheel motor and `slow` is a positive integer representing an appropriate turning speed.

```
move[left] ← slow
move[right] ← 0
```

The teacher suggests that the student consider modifying the robot's turning code to execute a point (in-place) turn rather than a swing turn. Which of the following code segments could the student use to implement the teacher's suggestion?

- A. `move[left] ← slow`
`move[right] ← -slow`
- B. `move[left] ← 0`
`move[right] ← slow`
- C. `move[left] ← slow`
`move[right] ← 2 * slow`
- D. `move[left] ← -slow`
`move[right] ← slow`

Answer _____

Competency 013—The computer science teacher knows game and mobile application development topics.

49. Consider a game in a two-dimensional space and the goal of determining whether a collision has occurred between two circular objects (that is, to detect whether two circular objects overlap or touch). The centers of the circular objects are stored in variables (x_1, y_1) and (x_2, y_2) and the radii are stored in variables r_1 and r_2 .

The distance between the two centers is given by the formula $\sqrt{(x_1 - x_2)^2 + (y_1 - y_2)^2}$.

The following pseudocode segment is intended to implement a collision-detection algorithm.

```
collision ← false
// dist is the distance between centers.
dist ← sqrt ( ( x1 - x2 )^2 + ( y1 - y2 )^2 )
if <missing condition> )
    collision ← true
end if
```

Which of the following could replace <missing condition> so that the collision detection algorithm works as intended?

- A. `dist ≥ r1 - r2`
- B. `dist ≤ r1 + r2`
- C. `(dist ≤ r1) or (dist ≤ r2)`
- D. `(dist ≤ r1) and (dist ≤ r2)`

Answer _____

50. When handling images in a video game, which of the following is a way of conserving memory?

- A. Using a floating-point data type for both integers and floating-point values
- B. Using a collection of tiles to create the game screen
- C. Using more than 24 bits for each RGB value
- D. Using higher resolution for all images

Answer _____

Preparation Manual

Section 4: Sample Selected-Response Answers and Rationales Computer Science 8–12 (241)

This section presents some sample exam questions for you to review as part of your preparation for the exam. To demonstrate how each competency may be assessed, sample questions are accompanied by the competency that they measure. While studying, you may wish to read the competency before and after you consider each sample question. Please note that the competency statements do not appear on the actual exam.

For each sample exam question, there is a correct answer and a rationale for each answer option. The sample questions are included to illustrate the formats and types of questions you will see on the exam; however, your performance on the sample questions should not be viewed as a predictor of your performance on the actual exam.

Domain I—Technology Applications Core

Competency 001—The computer science teacher knows technology terminology and concepts; the appropriate use of hardware, software and digital files; and how to acquire, analyze and evaluate digital information.

1. Which of the following is the principal advantage of saving a word processing document in rich-text format?
 - A. The document can be viewed in any Web browser.
 - B. A formatted document can be transferred between different applications.
 - C. The document can take up less space in memory.
 - D. A formatted document can be scanned for viruses when sent as an email attachment.

Answer

Option B is correct because most word processing applications can read and write rich-text format documents. **Option A is incorrect** because typical Web browsers do not support rich-text documents directly. **Option C is incorrect** because rich-text documents take up more space in memory than the corresponding documents in a plain text format or in the native format of the word processing application. **Option D is incorrect** because other formats can be scanned for viruses as well.

2. Which of the following would most likely be considered unacceptable use of information by a teacher?
 - A. Using the school district's database to determine gender distribution in local schools
 - B. Using the Internet history on a classroom computer to audit student Internet use
 - C. Using students' personal data to create a mailing list for a local charity
 - D. Using classroom records to determine recipients of academic awards

Answer

Option C is correct because it fails to protect personally identifiable information. **Option A is incorrect** because gender (by itself, without any other additional information) is not considered personally identifiable information and because aggregate statistics are computed. **Option B is incorrect** because students should have no expectations of privacy when accessing Internet content using a classroom computer. The school can monitor the network

usage in order to determine compliance with acceptable use guidelines. **Option D is incorrect** because classroom records are appropriate sources to use when selecting winners of academic awards.

3. Consider the uniform resource locator (URL) <https://example.net/index.html>. Which of the following are contained in the URL?

- A. Browser name
- B. Email address
- C. File name
- D. Host name
- E. MAC address
- F. Protocol

Answer

Options C, D, and F are correct. Option C is correct because the file name is indicated by index.html. **Option D is correct** because the hostname is indicated by example.net. **Option F is correct** because the protocol is indicated by https. **Options A, B, and E are incorrect** because the URL does not contain information about browser name, email address, or MAC address.

Competency 002—The computer science teacher knows how to use technology tools to solve problems, evaluate results and communicate information in a variety of formats for diverse audiences.

4. Students in a Texas classroom have been communicating with a class in New York by videoconference. The two classes find that the images they receive from each other occasionally freeze for up to 30 seconds before the video continues. This type of problem can most often be solved by

- A. increasing bandwidth.
- B. upgrading cameras.
- C. increasing video resolution.
- D. upgrading monitors.

Answer

Option A is correct because an increase in bandwidth will allow more data to be transferred and will help eliminate the freezing of the image. **Option B is incorrect** because updating cameras will not directly allow more data to be transferred. **Option C is incorrect** because increasing the video resolution will increase the amount of data to be transferred and could therefore cause the images to freeze for longer time periods. **Option D is incorrect** because upgrading monitors will not directly allow more data to be transferred.

5. Which of the following is the most appropriate format for graphics that are to be embedded within an Internet document?

- A. BMP
- B. TIFF
- C. PNG
- D. HTML

Answer

Option C is correct because PNG is a popular image format on the Internet because of its relatively small image size. Other Web-friendly image formats are GIF and JPEG. **Options A and B are incorrect** because BMP and TIFF images are typically very large. **Option D is incorrect** because HTML is not a format for graphics.

6. Suppose that the class grade for a six-week period is based on 3 tests (T1, T2, T3), each of which counts for 15%, 4 quizzes (Q1, Q2, Q3, Q4), each of which counts for 10%, and a homework notebook (HW), which counts for 15%. The grades are recorded in a spreadsheet similar to the one below.

	A	B	C	D	E	F	G	H	I	J
1	Name	T1	T2	T3	Q1	Q2	Q3	Q4	HW	AVG
2	Jane	87	92	80	76	79	87	74	90	
3	Joe	91	85	77	78	88	96	90	92	
4	Bill	65	72	70	80	81	74	77	80	
5	Brenda	96	88	91	76	91	100	74	98	

Which of the following formulas would be a correct calculation of the six-week weighted average for Jane?

- A. $=(B2+C2+D2+E2+F2+G2+H2+I2)/8$
- B. $=(B2+C2+D2+I2)*0.15+(E2+F2+G2+H2)*0.1$
- C. $=(B2+C2+D2+I2)*15+(E2+F2+G2+H2)*10$
- D. $=(B2+C2+D2+I2)/15+(E2+F2+G2+H2)/10$

Answer

Option B is correct because it demonstrates the correct computation of a weighted mean, where each value is multiplied by the corresponding percent value and then the results are summed. **Option A is incorrect** because it calculates the mean, not the weighted average. **Option C is incorrect** because it is the correct result multiplied by 100. **Option D is incorrect** because it uses division rather than multiplication.

Competency 003—The computer science teacher knows how to plan, organize, deliver and evaluate instruction that effectively utilizes current technology for teaching the Technology Applications Texas Essential Knowledge and Skills (TEKS) to all students.

7. A teacher has assigned students several topics to discuss outside of class using an electronic form of communication. The teacher wants the students' messages to be organized by topic and wants to have all historical messages available to students. To facilitate this type of communication most effectively, the teacher should have students

- A. participate in a threaded discussion group.
- B. send email messages with attached document files.
- C. update pages on the class's Web site.
- D. engage in dialogue in a real-time chat room.

Answer

Option A is correct because it meets both the requirement that the messages are organized by topic and the requirement that all old messages are available. **Option B is incorrect** because it does not meet either requirement. **Option C is incorrect** because updating a Web page to add a message is unnecessarily time-consuming and would likely lead to contention issues between students attempting to post messages simultaneously. **Option D is incorrect** because the messages will not be organized by topic.

8. A computer science teacher is going to have the students in a class read an article from a technology journal as homework. Which of the following instructional strategies best ensures that the students will fully understand the material?

- A. The teacher asks the students the following day if they fully understand the material.
- B. The teacher asks the students to take notes on the material as they are reading it.
- C. The teacher assigns problems or questions on key concepts for the students to complete after they have finished reading the material.
- D. The teacher reviews the material in a class presentation the following day and instructs the students to take notes on the presentation.

Answer

Option C is correct because students can demonstrate understanding by answering problems or questions on key concepts from the material. **Options A, B, and D are incorrect** because they do not include a robust way for students to demonstrate understanding of the material.

Domain II—Program Design and Development

Competency 004—The computer science teacher knows problem-solving strategies and different procedures for program design.

9. Consider the following flowchart diagram, where $\text{arr}[0..len-1]$ is an integer array of length len . Assume that the elements $\text{arr}[0]$, $\text{arr}[1]$, ..., $\text{arr}[len-1]$ have already been initialized.

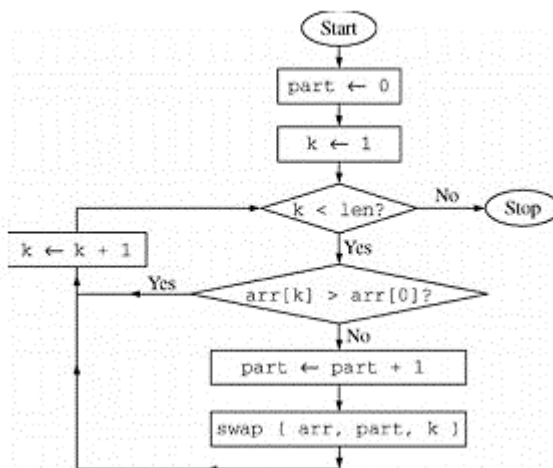

Which of the following pseudocode segments implements the algorithm in the flowchart?

- A. `int part ← 0`
`int k ← 1`
`while (k < len)`
 `if (arr[k] ≤ arr[0]`
 `part ← part + 1`
 `swap (arr, part, k)`
 `end if`
 `k ← k + 1`
`end while`
- B. `int part ← 0`
`int k ← 1`
`while(k < len)`
 `k ← k + 1`
 `if (arr[k] ≤ arr[0])`
 `part ← part + 1`
 `swap (arr, part, k)`
 `end if`
`end while`
- C. `int part ← 0`
`int k ← 1`
`while (k < len)`
 `if (arr[k] > arr[0])`
 `part ← part + 1`
 `swap (arr, part, k)`
 `end if`
 `k ← k + 1`
`end while`
- D. `int part ← 0`
`int k ← 1`
`while(k < len)`
 `k ← k + 1`
 `if (arr[k] > arr[0])`
 `part ← part + 1`
 `swap (arr, part, k)`
 `end if`
`end while`

Answer

Option A is correct because the code segment matches the steps in the flowchart. Two variables are initialized, followed by a `while` loop that is executed when `k < len`. Within the `while` loop, the condition on the `if` statement is the opposite of the corresponding condition in the flowchart, so `part` is updated and `swap` is called if the condition on the `if` statement is true. The variable `k` is incremented and the condition in the `while` loop is tested again. **Option B is incorrect** because the increment of `k` needs to occur after the `if` statement. **Option C is incorrect** because the increment of `part` and the call to the `swap` method need to occur when the

comparison `arr[k] > arr[0]` is false. **Option D is incorrect** for both of the reasons stated in options B and C.

10. Which of the following best describes the purpose of generating a flowchart as part of the design of a computer program?

- A. To test and maintain the efficiency of the overall program
- B. To present the steps needed to solve the programming problem
- C. To ensure that all methods are appropriately linked
- D. To determine the necessary number of global and local variables

Answer

Option B is correct because a flowchart is a graphic representation of a process, so it can be used to represent the steps in a computer program. **Option A is incorrect** because a flowchart is not a testing tool. **Options C and D are incorrect** because flowcharts cannot help to establish links between methods or analyze the variables used in a program.

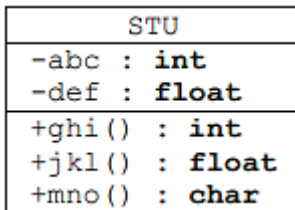

11. Which of the following best describes the information conveyed by the UML class diagram above?

- A. A class named `STU` contains two private fields and three public methods.
- B. A class named `STU` contains two public fields and three private methods.
- C. A class named `STU` contains two private methods and three public fields.
- D. A class named `STU` contains two public methods and three private fields.

Answer

Option A is correct. The UML class diagram consists of three stacked boxes. The top box contains the name of the class—`STU`. The middle box indicates that the `STU` class contains two fields—`abc` and `def`. The two fields are private as shown by the minus sign in front of the field names. Similarly, the bottom box indicates that the `STU` class contains three methods—`ghi()`, `jkl()`, and `mno()`. The three methods are public as indicated by the plus sign in front of the method names. **Option B is incorrect** because the two fields are private. **Options C and D are incorrect** because the class has two fields.

12. Consider the following algorithm for finding the maximum value in an integer array `x[0..n-1]` of length `n`, where the index of array `x` starts at 0.

- I. Initialize a variable, `max`, which will hold the largest value found in the array so far.
- II. Go through the array elements and compare each value to `max`.
- III. If a value is greater than `max`, set it as the new value of `max`.

IV. After going through the entire array, the maximum value in the array is the value of max .

Which of the following flowcharts represents the algorithm?

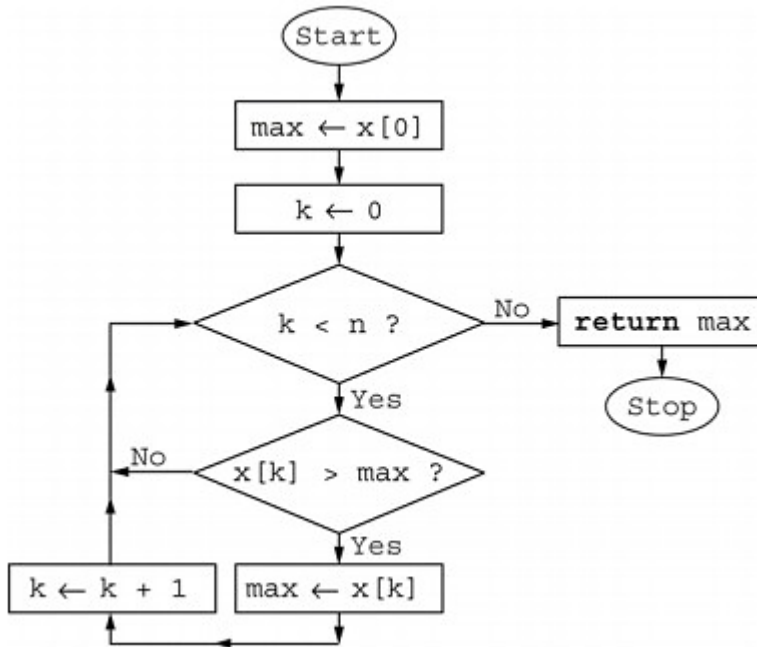

A.

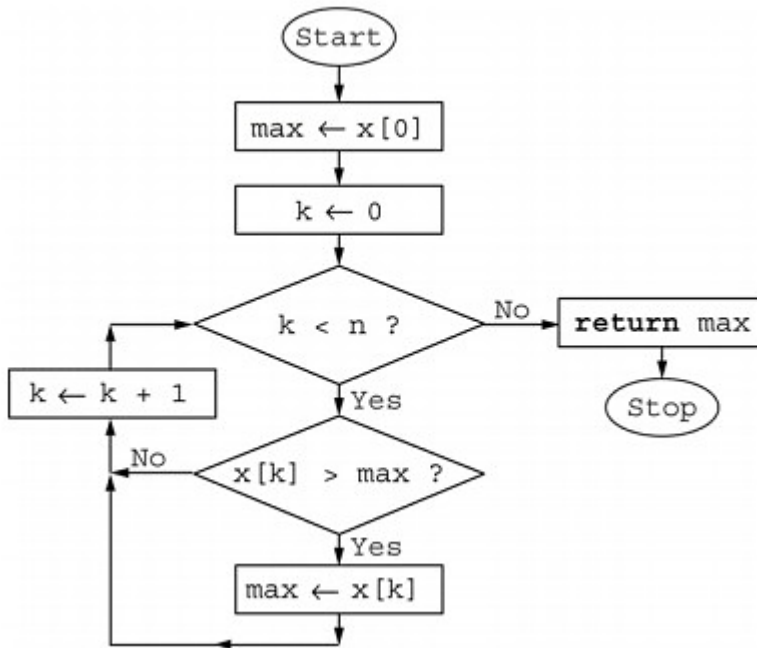

B.

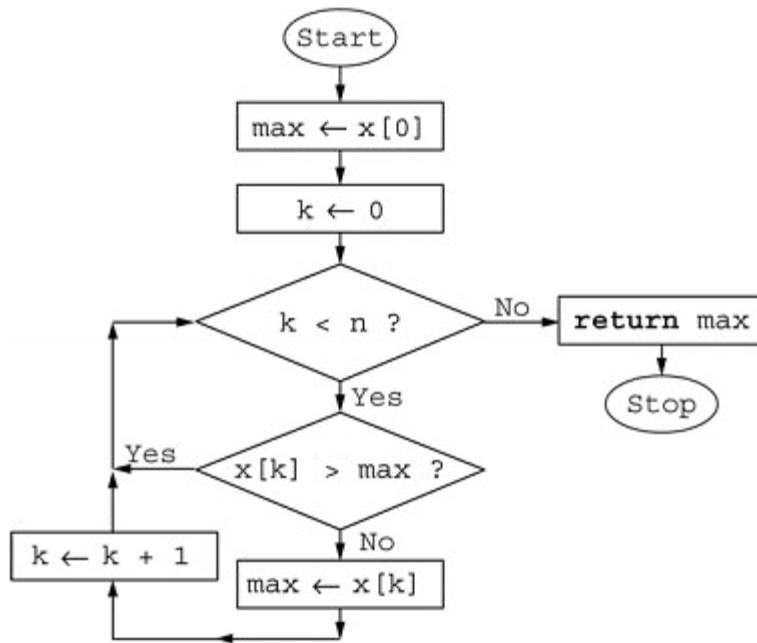

C.

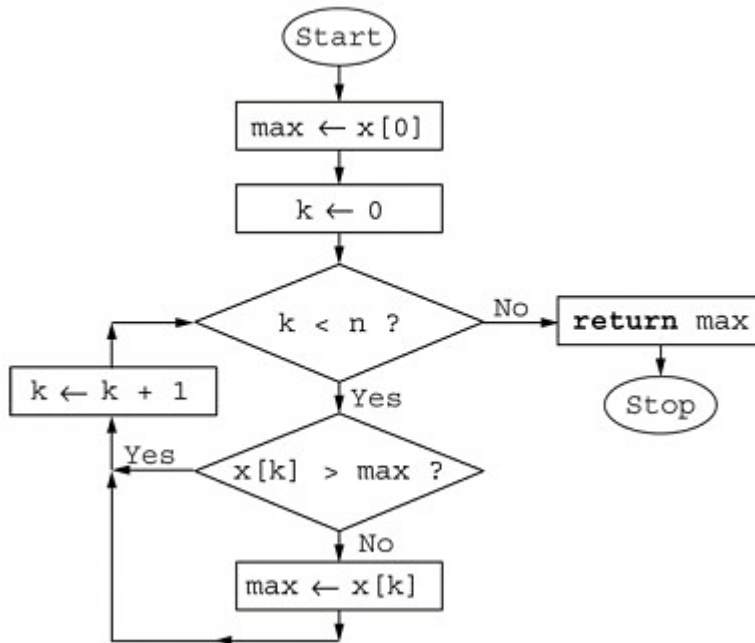

D.

Answer

Option B is correct because the flowchart matches the steps in the algorithm. The variable `max` is initialized to the first element in the array. An array index `k` is initialized to 0. If the condition `k < n` is false, the value of the variable `max` is returned and the algorithm stops. If the condition `k < n` is true, the array element `x[k]` is compared to `max`. If `x[k]` is larger than `max`, then the value of `x[k]` is set as the new value of `max`, the array index `k` is incremented by 1, and the flow returns back to the condition `k < n`; otherwise, the value of `max` is not changed, the array index `k` is incremented by 1, and the flow returns back to the condition `k < n`. **Option A is incorrect** because the increment of `k` should execute regardless of whether the condition `x[k] > max` is satisfied or not. **Option D is incorrect** because the Yes and No branches for the `x[k] > max` condition are switched. **Option C is incorrect** because it represents a combination of the issues in options A and D.

Competency 005—The computer science teacher knows procedures for software development and implementation.

13. A software system is to be developed for which the requirements are well understood and the risk of failure is minimal. To meet these requirements, which of the following software development models would be most appropriate to use?

- A. Chaos
- B. Incremental
- C. Spiral
- D. Waterfall

Answer

Option D is correct because waterfall is typically used when requirements are well understood and the risk of failure is minimal. **Options A, B, and C are incorrect** because those software development models are typically used in situations where the requirements are not well understood at the beginning of a project and change is anticipated.

14. The most appropriate way to use a library of program code is to access the

- A. methods or functions by way of the interface.
- B. implementation details of the methods or functions.
- C. methods or functions by way of the source code.
- D. documentation of the methods or functions.

Answer

Option A is correct because the methods or functions in a library are accessed using an interface. **Options B, C, and D are incorrect** because accessing the implementation details, source code, or documentation provides information about how the methods or functions work but does not provide access to their functionality.

15. Consider the following pseudocode segment with integer variables, where the precondition at the beginning of the segment is missing.

```
// missing precondition
x ← x + 1
y ← y + x
// postcondition: y == 2 * x
```

Which of the following would be a valid precondition for the code segment above?

- A. $y == x - 1$
- B. $y == x$
- C. $y == x + 1$
- D. $y == x + 2$

Answer

Option C is correct because the precondition $y == x + 1$ is equivalent to the postcondition $y == 2 * x$. If x_pre and y_pre are the values of x and y before the code segment and if x_post and y_post are the values of x and y after the code segment, then we have the following relations.

$$\begin{aligned}x_post &= x_pre + 1 \\y_post &= x_pre + y_pre + 1\end{aligned}$$

When x_post and y_post replace x and y in the postcondition $y == 2 * x$, we get $x_pre + y_pre + 1 = 2 * (x_pre + 1)$, or equivalently $y_pre = x_pre + 1$. **Option A is incorrect** because the given precondition is equivalent to the postcondition $y == 2 * x - 2$. **Option B is incorrect** because the given precondition is equivalent to the postcondition $y == 2 * x - 1$. **Option D is incorrect** because the given precondition is equivalent to the postcondition $y == 2 * x + 1$.

16. Consider the following pseudocode segment with floating point variables, where the function `squareRoot` is the standard square root function.

```
if ( /* missing condition */ )
    answer ← squareRoot ( a / ( b - c ) )
end if
```

Assume the programming language evaluates compound Boolean expressions from left to right and short-circuits the logical operators **and** and **or** as soon as the result of an expression is known. Which of the following could replace `/* missing condition */` so the code segment would not generate a run-time error?

- A. $b - c \neq 0$
- B. $a / (b - c) \geq 0$
- C. $(b - c \neq 0)$ **and** $(a / (b - c) \geq 0)$
- D. $(b - c \neq 0)$ **or** $(a / (b - c) \geq 0)$

Answer

Option C is correct. There are two run-time errors that might occur. The first one is a division-by-zero error which occurs when $b - c$ equals 0. The second is a not-a-number (NaN) error which occurs when taking the square root of a negative number. Both of these conditions must be checked prior to executing the body of the if statement. **Option A is incorrect** because $b - c \neq 0$ does not guarantee that $a / (b - c)$ is nonnegative, possibly leading to the evaluation of a square root of a negative number. **Option B is incorrect** because the evaluation of $a / (b - c)$ would generate a run-time error when the values of b and c are equal. **Option D is incorrect** because the logical operator **or** is short circuited as soon as $b - c \neq 0$ is satisfied, possibly leading to the evaluation of a square root of a negative number.

Competency 006—The computer science teacher knows computer science terminology and concepts and the characteristics of different programming languages and paradigms.

17. Which of the following techniques is used by most programming languages to intercept events that disrupt the normal flow of a program's execution?

- A. Code security
- B. Flow control
- C. Exception handling
- D. Error detection

Answer

Option C is correct because exception handling is used to intercept events. **Options A, B, and D are incorrect** because they refer to the presence of security holes in code, the flow of execution of programming statements, and the detection (but not necessarily handling) of errors in a program.

18. If execution speed and direct communication with devices such as controllers and processors are essential to the success of a project, which of the following programming languages would be most appropriate to use?

- A. C
- B. Java
- C. PHP
- D. Visual Basic

Answer

Option A is correct because C is a relatively small, efficient programming language that can be used to communicate directly with various devices. **Options B, C, and D are incorrect** because these languages are less appropriate to use when execution speed and direct communication with devices are essential.

19. How many bytes are needed for an array of 1,000 integers if each integer requires 32 bits of storage?

- A. 1,000 bytes
- B. 4,000 bytes
- C. 16,000 bytes
- D. 32,000 bytes

Answer

Option B is correct because an array of 1,000 integers is represented by a contiguous block of 1,000 integers and therefore requires $1,000 \times 32 = 32,000$ bits, or equivalently $32,000/8 = 4,000$ bytes. **Option A is incorrect** because 1,000 bytes is the number of bytes needed for an array of 250 integers. **Option C is incorrect** because 16,000 bytes is the number of bytes needed for an array of 4,000 integers. **Option D is incorrect** because 32,000 bytes is the number of bytes needed for an array of 8,000 integers.

20. Which of the following is unique to the object-oriented paradigm of programming?

- A. Support for abstract data types (ADTs)
- B. Support for the concepts of encapsulation and inheritance
- C. Support for control structures
- D. Support for the practice of code reuse

Answer

Option B is correct because encapsulation and inheritance are two of the fundamental concepts of the object-oriented programming paradigm and are not present in other programming paradigms. **Option A is incorrect** because ADTs are supported in many programming paradigms and are not unique to the object-oriented programming paradigm. **Option C is incorrect** because control structures are present in all programming paradigms and are not unique to the object-oriented programming paradigm. **Option D is incorrect** because code can be reused in all programming paradigms and this practice is not unique to the object-oriented programming paradigm.

Domain III—Programming Language Topics

Competency 007—The computer science teacher correctly and efficiently uses data types, data structures and functions in the development of code.

21. Which of the following is most efficient for manipulating a list that contains integers and is of predefined size?

- A. A stack
- B. A linked list
- C. An array
- D. A sequential file

Answer

Option C is correct because an array is most appropriate for traversing and updating a list with the given conditions. **Options A and B are incorrect** because stacks and linked lists do not have predefined sizes; they are intended to grow and shrink. **Option D is incorrect** because a sequential file does not provide easy access to individual elements and modifying individual elements is difficult.

22. A programmer is developing a program to read strings from a file and store the strings in a data structure. The strings are unordered in the file but must be accessible in alphabetical order in the data structure. The program must also be able to add and remove strings from the data structure.

Which of the following data structures is the best choice for the program so that the requirements for creating the data structure, adding and removing elements, and accessing individual elements are met as efficiently as possible?

- A. A binary search tree
- B. A linked list
- C. A queue
- D. A stack

Answer

Option A is correct. Of the data structures given the only one that maintains its elements in sorted order by default is the binary search tree. **Option B is incorrect.** A linked list can be used to maintain data in sorted order but requires sequential search to find an item to remove or to create the initial ordered list. **Options C and D are incorrect** because neither data structure facilitates the maintenance of a list in sorted order.

23. Consider the following pseudocode procedure `calc`, where the first and second parameters are passed by value and the third and fourth parameters are passed by reference. That is, actual parameters passed to formal parameters `w` and `x` are passed by value, while those passed to formal parameters `y` and `z` are passed by reference.

```
procedure calc ( pass-by-value int w,  
                pass-by-value int x,  
                pass-by-reference int y,  
                pass-by-reference int z )  
  
    w ← w + 1  
    x ← x * 2  
    y ← y + 3  
    z ← z * 4  
  
end procedure
```

What are the values of `a` and `b` at the end of the code fragment below?

```
int a ← 5  
int b ← 6  
calc ( a, a, b, b )
```

- A. `a = 5` and `b = 24`
- B. `a = 5` and `b = 36`
- C. `a = 10` and `b = 6`
- D. `a = 12` and `b = 6`

Answer

Option B is correct because at the end of the code fragment the values of `a` and `b` are 5 and 36, respectively. Since the first two parameters are passed by value, the value of `a` after the `calc` call is the same as the value of `a` before the `calc` call. Since the last two parameters are passed by reference, the parameters `y` and `z` point to variable `b`. The value of `b` at the end of the code fragment is the value of `z` at the end of the procedure. Since the value of `b` is originally 6, the value of `b` after `y ← y + 3` is 9, and the value of `b` after `z ← z * 4` is 36.

Option A is incorrect because it fails to recognize that `z` has the value 9 when the statement `z = z * 4` is executed, using the original value of 6 instead. **Option D is incorrect** because it confuses the meaning of pass-by-reference and pass-by-value. **Option C is incorrect** because it results from the errors present in both options A and D.

24. Consider a class `Stack` defined with methods `push (x)`, `pop ()` and `peek ()` that implement a stack data structure. (Note that `void push (int x)` pushes the integer `x` onto the top of the stack; `int pop ()` removes the integer at the top of the stack and returns that integer; `int peek ()` returns the integer at the top of the stack without removing it from the stack.)

Consider the following pseudocode fragment, where `S` is a `Stack` instance that will hold integers.

```
Stack S ← new Stack ()  
S.push ( 4 )  
S.push ( 3 )  
S.push ( S.peek () + S.peek () )  
S.push ( S.pop () * S.pop () )  
print ( S.peek () )
```

What is printed by the last line of code?

- A. 18
- B. 21
- C. 28
- D. 32

Answer

Option A is correct In the second and third lines of code, the values 4 and 3 are pushed onto the stack. In the fourth line of code, both peek operations return the value 3, so the value 6 is pushed onto the stack. In the fifth line of code, the two pop operations return 6 and 3, removing those values from the stack. Their product, 18, is then pushed onto the stack. The final line of code returns the value at the top of the stack, 18. **Options B, C, and D are incorrect** because they correspond to incorrect arithmetic operations or misconceptions about stack methods.

25. What is the sum of the binary (base 2) number 1100_2 and the hexadecimal (base 16) number 3_{16} ?

- A. F_{16}
- B. 15_{16}
- C. 1003_{10}
- D. 1103_{18}

Answer

Option A is correct. To add the two numbers, they must first be converted to the same base. Since $3_{16} = 0011_2$, the sum of the two numbers is $1100_2 + 0011_2 = 1111_2$, which is equal to the decimal number 15_{10} and also equal to the hexadecimal number F_{16} . **Options B and C are incorrect** because they are not equal to the decimal number 15_{10} or to the hexadecimal number F_{16} . **Option D is incorrect** because the sum is not computed by adding the numbers and by adding the two bases.

26. Consider the following array initialization, where array x has been declared properly but the declaration is not shown.

$x \leftarrow \{ 0, \{ 1, \{ 2, 3 \} \}, 4 \}$

Which of the following diagrams best represents array x ?

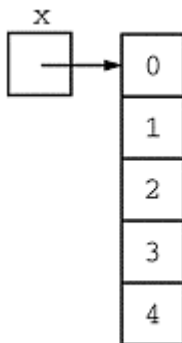

A.

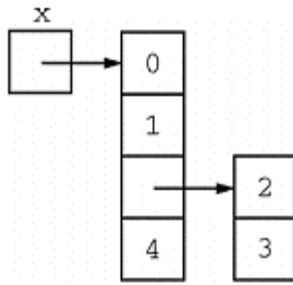

B.

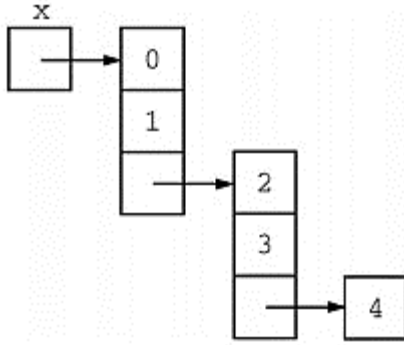

C.

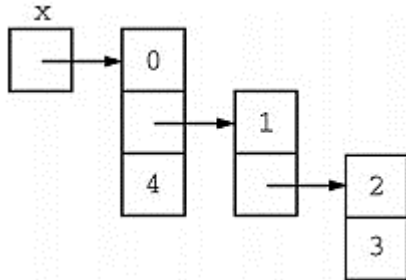

D.

Answer

Option D is correct because array x is an array with three elements, where the first element is 0, the second element is the array $\{ 1, \{ 2, 3 \} \}$, and the third element is 4. The array $\{ 1, \{ 2, 3 \} \}$ is an array with two elements, where the first element is 1 and the second element is the array $\{ 2, 3 \}$ with two elements, 2 and 3. **Option A is incorrect** because the diagram in option A represents the array $\{ 0, 1, 2, 3, 4 \}$. **Option B is incorrect** because the diagram in option B represents the array $\{ 0, 1, \{ 2, 3 \}, 4 \}$. **Option C is incorrect** because the diagram in option C represents the array $\{ 0, 1, \{ 2, 3, \{ 4 \} \} \}$.

27. Consider the following pseudocode segment, where x and y are integer arrays of length 5. The index of each array starts at 0.

```
int[] x ← { 1, 2, 3, 4, 5 }
int[] y ← { 8, 6, 4, 2, 0 }
```

What is the value of the expression $x[y[3]] + y[x[1]]$?

- A. 7
- B. 8
- C. 11
- D. 12

Answer

Option A is correct. Since the index of each array starts at 0, the value of $y[3]$ is 2, and the value of $x[2]$ is 3. Similarly, the value of $x[1]$ is 2, and the value of $y[2]$ is 4. The value of the expression $x[y[3]] + y[x[1]]$ is $3 + 4$, or 7. **Options B, C, and D are incorrect** because they correspond to the cases where the index of one or both of the arrays is assumed to start at 1.

28. Assume that a singly linked list of integers is implemented using the following pseudocode class declaration.

```
class Node
  int data
  Node next
end Node
```

Consider the following (incomplete) method g , which takes the head of a singly linked list of integers as argument.

```
void g ( Node x )
  if ( x ≠ null )
    /* missing code segment */
  end if
end g
```

Which of the following would correctly complete the method g so that the call $g (x)$ prints out the contents of x in reverse order?

- A. `print x.data`
`x ← x.next`
- B. `print x.data`
`g (x.next)`
- C. `g (x.next)`
`print x.data`
- D. `g (x)`
`print x.data`

Answer

Option C is correct because the `print x.data` statement follows the recursive call `g (x.next)`, resulting in the contents of x being printed in the reverse order. **Option A is incorrect** because it prints the contents of x in order. **Option B is incorrect** because it also prints the contents of x in order. **Option D is incorrect** because it produces an infinite loop.

Competency 008—The computer science teacher correctly and efficiently uses statements and control structures in the development of code.

29. Consider the following pseudocode functions, where each print statement prints on a separate line of output and then executes a line feed.

```
void f1 ( int n )
  int k ← 0
  do {
    k ← k + 1
    print k
```

```

    } while ( k < n )
end f1
void f2 ( int n )
    int k ← 0
    while ( k < n )
        k ← k + 1
        print k
    end while
end f2

```

Which of the following describes all the values of the input n for which functions $f1$ and $f2$ print the same sequence of numbers?

- A. $n > 0$
- B. $n \geq 0$
- C. $n < 0$
- D. $n \leq 0$

Answer

Option A is correct because when n is a positive integer the two functions print the same sequence of numbers. **Options B, C, and D are incorrect** because when n is 0 or negative, the **do-while** loop in function $f1$ is executed once and prints one number; the **while** loop in function $f2$ is never entered and no numbers are printed.

30. Consider the following pseudocode fragment, where x is an integer variable initialized to a nonnegative integer value.

```

// x is a nonnegative integer
int sum
x ← x / 2 // integer division; truncates fractions
for (sum ← 1; x > 0; x ← x / 2 )
    sum ← sum + 1
end for

```

Which of the following will calculate the same value of sum as the fragment above?

- A.

```
int sum ← 0
x ← x / 2
while ( x ≥ 0 )
    sum ← sum + 1
    x ← x / 2
end while
```
- B.

```
int sum ← 1
x ← x / 2
while ( x ≥ 0 )
    sum ← sum + 1
    x ← x / 2
end while
```

```
C. int sum ← 0
   do {
       sum ← sum + 1
       x ← x / 2
   } while ( x > 0 )
```

```
D. int sum ← 1
   do {
       sum ← sum + 1
       x ← x / 2
   } while ( x > 0 )
```

Answer

Option C is correct because the given **do-while** loop is equivalent to the given **for** loop. **Options A and B are incorrect** because the value of x will eventually become 0 and the while loop will loop forever. **Option D is incorrect** because the variable `sum` needs to be initialized to 0.

31. Consider the following pseudocode fragment with integer variables.

```
total ← 0
x ← 1

while ( x < ( 2 * n ) )
    if ( ( x % 2 ) == 1 ) // if x is odd
        total ← total + x
    end if
    x ← x + 1
end while

print ( total )
```

Assume that n has been initialized with a positive integer value. What value is printed when the code fragment is executed?

- A. 0
- B. n
- C. $2n$
- D. n^2

Answer

Option D is correct. The code segment adds all the positive odd numbers less than $2n$ and prints the sum. Since $1 + 3 + 5 + \dots + (2n - 1) = n^2$, the correct answer is D. **Options A, B, and C are incorrect** because they do not represent the printed value.

32. In a distribution center, x identical items are to be placed into a number of identical boxes. If at most y items fit in a box, which of the following expressions describes the maximum possible number of full boxes? (In the expressions below, $/$ represents decimal division and \backslash represents integer division.)

- A. x / y
- B. $(x / y) + (x \% y)$
- C. $x \setminus y$
- D. $(x \setminus y) + (x \% y)$

Answer

Option C is correct because the maximum possible number of full boxes is equal to the result of the integer division of x , the total number of items, by y , the maximum number of items a box will hold. **Options A and B are incorrect** because they return real numbers that may have fractional components. **Option D is incorrect** because it adds the remainder of the integer division to the result of the integer division.

33. Consider the following arithmetic expression.

$$6 / 3 - 7 \% 2 + 4 * 5$$

According to standard operator precedence and standard operator associativity, what is the fourth operation performed when calculating the value of the expression?

- A. Addition
- B. Modulus (remainder)
- C. Multiplication
- D. Subtraction

Answer

Option D is correct. Division, modulus, and multiplication have the same precedence and have higher precedence than addition and subtraction. Since the associativity for division, modulus, and multiplication is left to right, the first operation performed is division, the second operation is modulus, and the third operation is multiplication. Addition and subtraction have the same precedence and their associativity is also left to right, so the fourth operation is subtraction and the fifth operation is addition. **Option A is incorrect** because addition is the fifth operation performed. **Option B is incorrect** because modulus is the second operation performed. **Option C is incorrect** because multiplication is the third operation performed.

34. Consider an integer array x of length 25, where the index of the array starts at 0. Which of the following pseudocode segments prints the elements of the array in reverse order?

- A.

```
for ( int i ← 0; i < 25; i ← i + 1 )
    print x[i + 1]
end for
```
- B.

```
for ( int i ← 0; i < 25; i ← i + 1 )
    print x[i]
end for
```
- C.

```
for ( int i ← 25; i > 0; i ← i - 1 )
    print x[i - 1]
end for
```
- D.

```
for ( int i ← 25; i > 0; i ← i - 1 )
    print x[i]
end for
```

Answer

Option C is correct because the array elements are printed in decreasing order of their index, and the code segment prints all the array elements from $x[24]$ to $x[0]$. **Option A is incorrect** because the array elements are printed in increasing order of their index, the print starts with $x[1]$, and there is an array index out-of-bounds error when $x[25]$ is evaluated. **Option B is incorrect** because the array elements are printed in increasing order of their index. **Option D is incorrect** because there is an array index out-of-bounds error when $x[25]$ is evaluated and because $x[0]$ is never printed.

Competency 009—The computer science teacher knows how to construct, compare and analyze various algorithms.

35. Which of the following represents the average-case performance of a quicksort algorithm?

- A. $O(n)$
- B. $O(\log_2 n)$
- C. $O(n^2)$
- D. $O(n \log_2 n)$

Answer

Option D is correct because on average the quicksort algorithm takes $O(n \log_2 n)$ comparisons to sort n items. **Options A, B, and C are incorrect** because they are not equivalent to $O(n \log_2 n)$.

36. Consider the following pseudocode function, where each print statement prints on a separate line of output and then executes a line feed.

```
void h ( int n )
    if ( n ≥ 4 )
        h ( n / 2 )
    end if
    print n
end h
```

What is printed when the call `h (16)` is executed?

- A. 2
- B. 16
- C. 16
8
4
2
- D. 2
4
8
16

Answer

Option D is correct because the call `h(16)` prints four lines of output containing the numbers 2, 4, 8, and 16, respectively. It first calls `h(8)` and then will print 16 on a new line after the call `h(8)` completes. The call `h(8)` calls `h(4)` and then will print 8 on a new line after the call `h(4)` completes. The call `h(4)` calls `h(2)` and then will print 4 on a new line after the call `h(2)` completes. The call `h(2)` prints 2, the first value printed. As each recursive call returns, the values 2, 4, 8, and 16 are printed. **Options A, B, and C are incorrect** because they correspond to misconceptions about how recursive functions work.

37. A specific sorting algorithm begins by finding the largest element of an array and swapping that element with the last element of the array. Which of the following sorting algorithms fits this description?

- A. Quicksort
- B. Insertion sort
- C. Heapsort
- D. Selection sort

Answer

Option D is correct because the question describes how selection sort works. **Option A is incorrect** because quicksort uses a partition operation to divide the input array into two smaller sub-arrays and then sorts the sub-arrays recursively. **Option B is incorrect** because, in each iteration, insertion sort removes one element from the input, finds its correct location in the part already sorted and inserts it there. **Option C is incorrect** because heapsort uses a heap data structure.

38. Consider the following pseudocode binary search function, which returns the largest array index from one given index to another, k , such that $a[k] \leq x$.

```
// precondition 1: integer array a is sorted in
//           ascending order
// precondition 2: 0 ≤ first < last < length of array a
// precondition 3: a[first] ≤ x < a[last]
int f ( int array a, int x, int first, int last )
    while ( first + 1 ≠ last )
        int mid ← ( first + last ) / 2 // integer
                                // division
        if ( x < a[mid] )
            last ← mid
        else
            first ← mid
        end if
    end while
    return first
end f
```

Consider the following incomplete, equivalent, recursive implementation.

```
Int g ( int array a, int x, int first, int last )
    if ( first + 1 == last )
        return first
```

```

    end if
    int mid ← ( first + last ) / 2
    // missing code block
end g

```

Which of the following could replace the missing code block so that the recursive function will work as intended?

- A. `if (x ≥ a[mid])`
 `return g (a, x, first, mid)`
 `end if`
 `return g (a, x, mid, last)`
- B. `if (x ≥ a[mid])`
 `return g (a, x, mid, first)`
 `end if`
 `return g (a, x, last, mid)`
- C. `if (x ≥ a[mid])`
 `return g (a, x, mid, last)`
 `end if`
 `return g (a, x, first, mid)`
- D. `if (x ≥ a[mid])`
 `return g (a, x, last, mid)`
 `end if`
 `return g (a, x, mid, first)`

Answer

Option C is correct because, if $x \geq a[\text{mid}]$, the value x could only be in $a[\text{mid}.. \text{last}]$; otherwise, the value x could only be in $a[\text{first}.. \text{mid}]$. **Options A, B, and D are incorrect** because they correspond to misconceptions about how binary search works.

39. Consider the following pseudocode function.

```

// precondition: n and k are nonnegative integers
int f ( int n, int k )
    if ( k * n == 0 )
        return 1
    else
        return f ( n - 1, k - 1 ) + f ( n - 1, k )
    end if
end f

```

What value is returned by the call `f (4, 2)` ?

- A. 4
 B. 5

C. 7

D. 11

Answer

Option D is correct because the value returned by the call $f(4, 2)$ is 11.

$$\begin{aligned} f(4, 2) &= f(3, 1) + f(3, 2) \\ &= f(2, 0) + f(2, 1) + \\ &\quad f(2, 1) + f(2, 2) \\ &= 1 + 2 * f(2, 1) \\ &\quad + f(2, 2) \\ &= 1 + 2 * (f(1, 0) + \\ &\quad f(1, 1)) + (f(1, 1) \\ &\quad + f(1, 2)) \\ &= 3 + 3 * f(1, 1) \\ &\quad + f(1, 2) \\ &= 3 + 3 * (f(0, 0) + \\ &\quad f(0, 1)) + (f(0, 1) \\ &\quad + f(0, 2)) \\ &= 11 \end{aligned}$$

Options A, B, and C are incorrect because they correspond to misconceptions about how recursive functions work.

40. Consider the following pseudocode segment with integer variables that implements a selection sort. Assume that A is an integer array of length n with indexing that starts at 0.

```
for ( int j ← 0; j < n - 1; j ← j + 1 )
  int x ← j
  for ( int i ← j + 1; i < n; i ← i + 1 )
    // missing code block
  end for
  if ( x ≠ j )
    swap ( A[x], A[j] ) // swap the two array entries
  end if
end for
```

Which of the following could replace the missing code block so that the code segment will work as intended?

A. **if** ($A[x] > A[i]$)

$x \leftarrow i$

end if

B. **if** ($A[x] > A[i]$)

$A[x] \leftarrow A[i]$

end if

```

C. if ( x > i )
    x ← i
end if

D. if ( x > i )
    A[x] ← A[i]
end if

```

Answer

Option A is correct. In each iteration of the outer `for` loop, the inner `for` loop identifies the smallest value in subarray `A[j+1..n-1]` and the `if` statement swaps it with `A[j]`. **Option B is incorrect** because it overwrites `A[x]` rather than updates variable `x`. **Option C is incorrect** because it compares the indexes of array elements rather than the array values. **Option D is incorrect** because it results from the errors present in both options B and C.

41. Consider the following pseudocode, which implements an insertion sort.

```

// precondition 1: A is an array of integers.
// precondition 2: The length of array A is n.
// precondition 3: The index of array A starts at 0.
int[] insertionSort ( pass-by-reference int[] A, int n )
    for ( int j ← 1; j ≤ n - 1; j ← j + 1 )
        int temp ← A[j]
        int k ← j - 1
        while( ( k ≥ 0 ) and ( A[k] > temp ) )
            A[k + 1] ← A[k]
            k ← k - 1
        end while
        A[k + 1] ← temp
    end for
    return A // returns the sorted array
end insertionSort

```

Which of the following best describes the average running time of `insertionSort`?

- A. $O(1)$
- B. $O(\log n)$
- C. $O(n \log n)$
- D. $O(n^2)$

Answer

Option D is correct because on average the insertion sort takes $O(n^2)$ to sort n items. **Options A, B, and C are incorrect** because they are not equivalent to $O(n^2)$.

42. Consider the following three pseudocode procedures.

```
Procedure 1
procedure p1 ( int s, int e )
    int k
    for ( k ← s; k < e; k ← k + 2 )
        print ( k )
    end for
end procedure p1
```

```
Procedure 2
procedure p2 ( int s, int e )
    do {
        s ← s + 2
        print ( s )
    } while ( s < e )
end procedure p2
```

```
Procedure 3
procedure p3 ( int s, int e )
    print ( s )
    if ( s < e )
        p3 ( s + 2 )
    end if
end procedure p3
```

Assume that s and e have been initialized with integer values. Which of the following statements about the output of the procedures is true?

- A. For each pair (s, e) , the three procedures will produce the same output.
- B. For each pair (s, e) , procedure 1 and procedure 2 will produce the same output, but for some pairs (s, e) , procedure 1 and procedure 3 will produce different output.
- C. For each pair (s, e) , procedure 2 and procedure 3 will produce the same output, but for some pairs (s, e) , procedure 1 and procedure 2 will produce different output.
- D. For some pairs (s, e) , the three procedures will produce three different outputs.

Answer

Option D is correct because the three procedures will produce three different outputs when s is 1 and e is 2. For this pair, procedure 1 will print 1, procedure 2 will print 3, and procedure 3 will print 1 and 3. **Options A, B, and C are incorrect** because the three procedures will produce three different outputs for the pair $(1, 2)$.

Domain IV—Specialized Topics

Competency 010—The computer science teacher knows discrete mathematics topics relevant to computer science.

43. Which of the following truth tables correctly represents the Boolean expression $(p \wedge q) \leftrightarrow (p \vee q)$?

A.	p	q	$(p \wedge q) \leftrightarrow (p \vee q)$
	1	1	0
	1	0	1
	0	1	1
	0	0	0

B.	p	q	$(p \wedge q) \leftrightarrow (p \vee q)$
	1	1	1
	1	0	0
	0	1	0
	0	0	1

C.	p	q	$(p \wedge q) \leftrightarrow (p \vee q)$
	1	1	1
	1	0	1
	0	1	1
	0	0	0

D.	p	q	$(p \wedge q) \leftrightarrow (p \vee q)$
	1	1	1
	1	0	0
	0	1	0
	0	0	0

Answer

Option B is correct. The table below shows the complete truth table.

p	q	$p \wedge q$	$p \vee q$	$(p \wedge q) \leftrightarrow (p \vee q)$
1	1	1	1	1
1	0	0	1	0
0	1	0	1	0
0	0	0	0	1

Option A is incorrect because it's the negation of the correct values. **Option C is incorrect** because it results from using "or" instead of "if and only if." **Option D is incorrect** because it results from using "and" instead of "if and only if."

44. Consider propositions p and q , defined as follows.

p : I go for a run.

q : The sky is dark.

Which of the following is equivalent to the compound proposition "I don't go for a run when the sky is dark"?

- A. $p \Rightarrow q$
- B. $\neg p \Rightarrow q$
- C. $q \Rightarrow \neg p$
- D. $\neg q \Rightarrow p$

Answer

Option C is correct because the compound statement is equivalent to "If the sky is dark, then I don't go for a run," which is represented by $q \Rightarrow \neg p$. **Option A is incorrect** because $p \Rightarrow q$ is equivalent to "If I go for a run, then the sky is dark." **Option B is incorrect** because $\neg p \Rightarrow q$ is equivalent to "If I don't go for a run, then the sky is dark." **Option D is incorrect** because $\neg q \Rightarrow p$ is equivalent to "If the sky is not dark, then I go for a run."

45. If p and q are propositions, which of the following is the contrapositive of the implication $p \Rightarrow q$?

- A. $q \Rightarrow p$
- B. $\neg q \Rightarrow \neg p$
- C. $q \vee p$
- D. $q \wedge p$

Answer

Option B is correct because the contrapositive is obtained by switching the hypothesis and the conclusion and negating both of them. **Option A is incorrect** because it represents the converse. **Option C is incorrect** because it represents the disjunction of hypothesis and conclusion. **Option D is incorrect** because it represents the conjunction of hypothesis and conclusion.

Competency 011—The computer science teacher knows digital forensics topics.

46. Which of the following describes how data remanence is relevant to digital forensics?

- A. It allows the recovery of digital data even though file deletion has occurred.
- B. It determines whether data are preserved or lost when a computer is turned off.
- C. It ensures that collected evidence is admissible as evidence in a court of law.
- D. It establishes who has authorization to monitor and collect network traffic data.

Answer

Option A is correct because data remanence refers to the data that remain on a storage device after data are deleted. **Options B, C, and D are incorrect** because they do not describe how data remanence is relevant to digital forensics.

47. Which of the following best describes a computer worm?

- A. Malware that does not replicate itself but spreads through social engineering
- B. Malware that replicates by attaching itself to a word processing document
- C. Malware that replicates by attaching itself to an executable program
- D. Malware that replicates itself as stand-alone software

Answer

Option D is correct because a computer worm is a stand-alone malware software application that replicates itself in order to spread to other computers. **Option A is incorrect** because a computer worm replicates itself. **Options B and C are incorrect** because a computer worm is a stand-alone software application and does not necessarily need to attach itself to other programs.

Competency 012—The computer science teacher knows robotics topics.

48. A robot's programming system uses the command `move[motor] ← value`, where `motor` identifies a particular motor and `value` is an integer amount of speed, with a positive value indicating forward movement, a negative value indicating backward movement, and 0 indicating a stop. For example, the command `move[left] ← 99` will cause the left motor to move forward at a speed of 99.

A student is programming a two-wheel-drive robot to travel through a maze and is having trouble with the corners. The robot swings wide and goes out of bounds. A segment of the code being used for a right turn is similar to the code below, where `left` is the left wheel motor (from the robot's perspective), `right` is the right wheel motor and `slow` is a positive integer representing an appropriate turning speed.

```
move[left] ← slow
move[right] ← 0
```

The teacher suggests that the student consider modifying the robot's turning code to execute a point (in-place) turn rather than a swing turn. Which of the following code segments could the student use to implement the teacher's suggestion?

- A. `move[left] ← slow`
`move[right] ← -slow`
- B. `move[left] ← 0`
`move[right] ← slow`
- C. `move[left] ← slow`
`move[right] ← 2 * slow`
- D. `move[left] ← -slow`
`move[right] ← slow`

Answer

Option A is correct because the algorithm for performing an in-place turn is to set the motors to turn at the same speed in opposite directions. To generate a right turn, the left wheel should go forward, and the right wheel should go backward. **Options B and C are incorrect** because each executes a swing turn to the left. **Option D is incorrect** because it executes an in-place left turn.

Competency 013—The computer science teacher knows game and mobile application development topics.

49. Consider a game in a two-dimensional space and the goal of determining whether a collision has occurred between two circular objects (that is, to detect whether two circular objects overlap or touch). The centers of the circular objects are stored in variables (x_1, y_1) and (x_2, y_2) and the radii are stored in variables r_1 and r_2 .

The distance between the two centers is given by the formula $\sqrt{(x_1 - x_2)^2 + (y_1 - y_2)^2}$.

The following pseudocode segment is intended to implement a collision-detection algorithm.

```
collision ← false
// dist is the distance between centers.
dist ← sqrt ( ( x1 - x2 )^2 + ( y1 - y2 )^2 )
if <missing condition> )
    collision ← true
end if
```

Which of the following could replace <missing condition> so that the collision detection algorithm works as intended?

- A. $\text{dist} \geq r_1 - r_2$
- B. $\text{dist} \leq r_1 + r_2$
- C. $(\text{dist} \leq r_1)$ **or** $(\text{dist} \leq r_2)$
- D. $(\text{dist} \leq r_1)$ **and** $(\text{dist} \leq r_2)$

Answer

Option B is correct because a collision occurs whenever the distance between the two centers is less than or equal to the sum of the two radii. **Options A, C, and D are incorrect** because they do not describe the complete conditions when a collision occurs.

50. When handling images in a video game, which of the following is a way of conserving memory?

- A. Using a floating-point data type for both integers and floating-point values
- B. Using a collection of tiles to create the game screen
- C. Using more than 24 bits for each RGB value
- D. Using higher resolution for all images

Answer

Option B is correct because when using a collection of tiles, the portions of the scene not in use will not consume valuable memory. **Options A, C, and D are incorrect** because each of the actions will increase memory use.